

Data Sheet

Type Description : Low Offset Voltage Dual
Operational Amplifier

Product Name : EST.4310A

Reversion : V1.0

Reversion Date : May, 2016

Page : 11 Pages

GENERAL DESCRIPTION

The EST.4310A integrates a low power, low offset and high performance Independent operational amplifier.

The EST.4310A also provides a same specification operational amplifier but with a 2.5V voltage reference connected to its non-inverting input terminal.

Now, it is available in a tiny SOP-8 and TSSOP-8 package

PIN CONFIGURATION

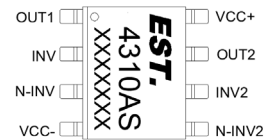
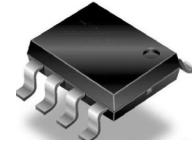

APPLICATION

- Switching ac/dc adapter and battery charger
- ATX standby power
- Open frame switching power and CD(R)
- Set-top-boxes(STB) 384Xreplacement

FEATURE

- Operational Amplifier
- Power supply range : 6V(+/-3V) to 26V(+/-13V)
- Low supply current : 300uA/channel (@ VCC+=20V)
- Low input offset voltage : $\pm 150\mu\text{V}$
- Low input offset voltage drifting : $7\mu\text{V}/^\circ\text{C}$
- Unity gain bandwidth : 1MHz
- Wide input common mode range : $0\text{V} \sim \text{VCC}+$
- Built-in reference voltage: $2.5\text{V} \pm 0.4\%$
- Low build up current : 20uA
- Sink current capability : 150mA

APPLICATION CIRCUIT

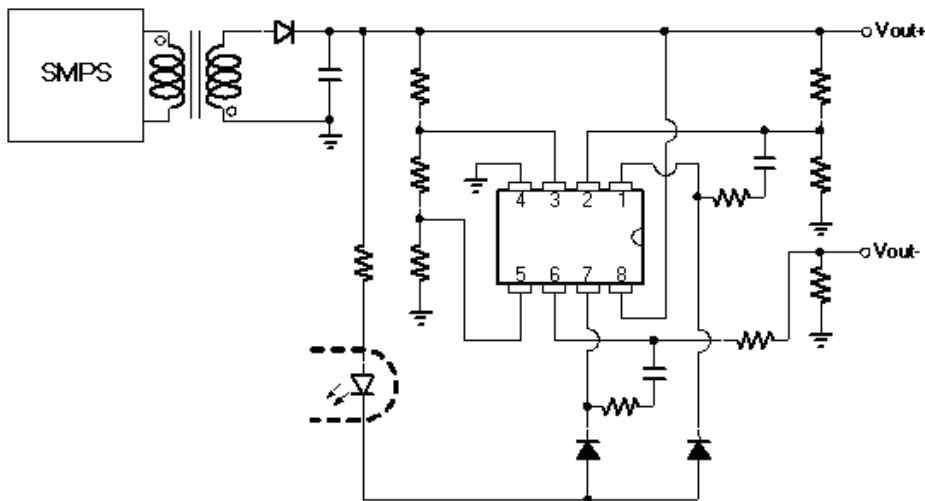

ORDERING INFORMATION

Part Number	Package	Packaging	Note	Top Marking
EST.4310AS	SOP-8	Tube	Green	EST.4310AS
EST.4310ASR	SOP-8	Tape & Reel	Green	EST.4310AS
EST.4310AT	TSSOP-8	Tube	Green	EST.4310AT
EST.4310ATR	TSSOP-8	Tape & Reel	Green	EST.4310AT

Note: EST lead-free products contain molding compounds/die attach materials and 100% matte tin plate termination finish; which are fully compliant with RoHS .EST lead-free products meet or exceed the lead-free requirements of IPC/JEDEC J-STD-020C for MSL classification at lead-free peak reflow temperature. EST defines "Green" to mean lead-free (RoHS compliant) and halogen free (Br or Cl does not exceed 900ppm by weight in homogeneous material and total of Br and Cl does not exceed 1500ppm by weight).

PIN DESCRIPTION

SOP-8	NAME Description	Description
1	OUT1	OP1 output
2	INV1	OP1 Inverting Input
3	NINV1	OP1 Non-inverting Input
4	VCC-	Ground for Single supply/ Negative power supply
5	NINV2	OP2 Non-inverting Input
6	INV2	OP2 Inverting Input
7	OUT2	OP2 Output
8	VCC+	Positive power supply

ABSOLUTE MAXIMUM RATINGS

Parameter Symbol	Symbol	Limit Values		Unit	Remark
		Min.	Max		
Supply Voltage Vcc	V_{CC}	-0.3	26	V	
Differential Input Voltage	V_{ID}	6	26	V	
Input Voltage	V_i	-0.6	26	V	
OP Output Voltage	V_o	-0.3	Vcc	mV	
Operation Junction Temperature	T_j	-40	150	°C	
Storage Temperature	T_{stg}	-55	150	°C	
Package Thermal Resistance	SOP-8	θ_{JA}	-	180	°C/W
Power Dissipation @TA<50°C	SOP-8	PD	-	0.42	W
Package Thermal Resistance	TSSOP-8	θ_{JA}	-	270	°C/W
Power Dissipation @TA<50°C	TSSOP-8	PD	-	0.28	W
Lead temperature (Soldering, 10 sec)			-	260	°C
ESD Voltage Protection	HBM	VESD-HBM	-	3.0	KV
	MM	VESD-MM	-	300	V

Stress beyond those listed under “Absolute Maximum Ratings” may cause permanent damage to the device. These are stress ratings only, and functional operation of the device at these or any other conditions beyond those indicated in the operational sections of the specifications is not implied. Exposure to absolute maximum rating conditions for extended periods may affect device reliability.

*Free standing with no heatsink; without copper clad.(Measurement condition – just before junction temperature T_j enters into OTP)

**Measure on the PKG top surface

BLOCK DIAGRAM

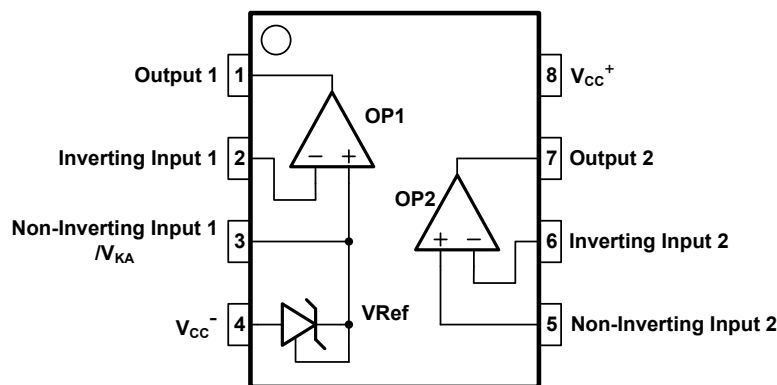

CAUTION

This integrated circuit has been designed carefully in the ESD protection ability. Failure to observe proper handling and installation procedures may cause damage. Recommend that all integrated circuits should be handled with appropriate precautions.

DC ELECTRICAL CHARACTERISTICS ($V_{CC^+} = 15V$, $V_{CC^-} = 0V$ $T_a = 25^\circ C$)

Operational Amplifier :

Parameter	Symbol	Min.	Typ.	Max.	Unit	Conditions
Positive Supply Voltage	V_{CC^+}	6		26	V	
Total Supply Current	I_{CC}			300	μA	1. $V_{CC} = 15V$ 2. no load,
Input Offset Voltage	V_{IO}	-150 -250	0 0	150 250	μV	25°C -25~85°C
Small Signal Gain	A_{VD}		80		dB	
Supply Voltage Rejection Ratio	SVR		80		dB	$V_{CC^+} = 9V$ to 20V
Input Common Mode Voltage Range	V_{ICM}	0		V_{CC}	V	
Common Mode Rejection Ratio	C_{MR}			80	dB	
Output Current Source	I_{SOURCE}			20	mA	1. $V_{ID} = +1V$ 2. $V_{CC} = 15V$ 3. $V_O = 2V$
Output Current Sink	I_{SINK}		15		mA	1. $V_{ID} = -1V$ 2. $V_{CC} = 15V$ 3. $V_O = 2V$
High Level Output Voltage	V_{OH}			V_{CC}	V	1. $R_L = 10K$ 2. $V_{CC^+} = 20V$
Low Level Output Voltage	V_{OL}		20		mV	$R_L = 10K$
Slew Rate at Unity Gain	SR		0.5		V/ μs	1. $V_i = 0.5$ to 3V 2. $V_{CC} = 15V$ 3. $R_L = 2K$ 4. $C_L = 100pF$ 5. unity gain connection
Gain Bandwidth Product	GBP		1		MHz	1. $f = 100KHz$ 2. $V_{CC} = 20V$ 3. $R_L = 2K$ 4. $C_L = 100pF$
Cathode Current	I_K	0.1		150	mA	
Reference Output Voltage	V_{REF}	2.49	2.5	2.51	V	$T_a = +25^\circ C$
		2.485		2.525	V	$-25^\circ C \leq T_a \leq +100^\circ C$
Reference Input Voltage Deviation Over Temperature Range	ΔV_{REF}		7		mV	1. $I_K = 10mA$ 2. -25 ~ 100°C
Minimum Cathode Current for Regulation	I_{MIN}		20		μA	$V_{KA} = V_{REF}$
Dynamic Impedance	$ Z_{KA} $		0.2	0.5	ohm	1. $V_{KA} = V_{REF}$ 2. $\Delta I_K = 1$ to 100mA 3. $Z = \Delta V_{KA} / \Delta I_K$

APPLICATION NOTE

Typical Applications (single supply voltage) $V_{CC}=+5V_{DC}$

Figure 1. AC coupled inverting amplifier

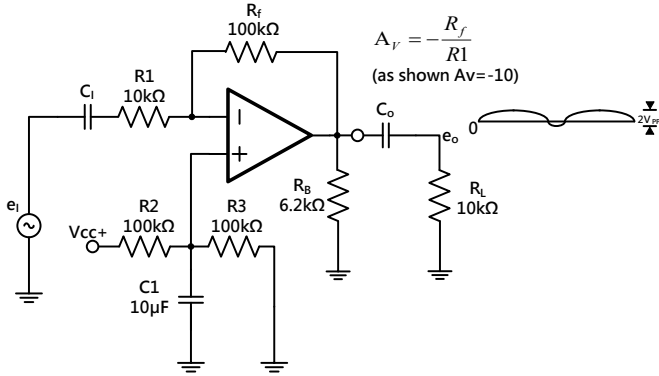

Figure 2. Non-inverting DC amplifier

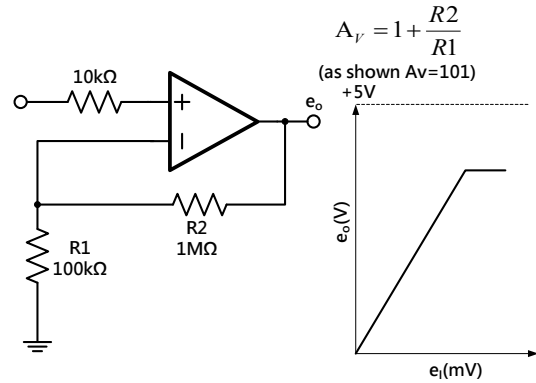

Figure 3. AC coupled non-inverting amplifier

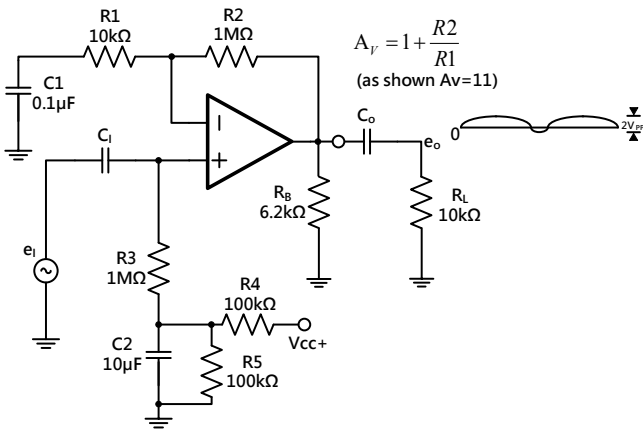

Figure 4. DC summing amplifier

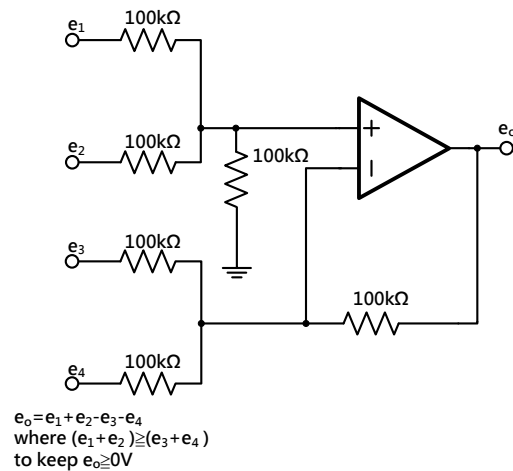
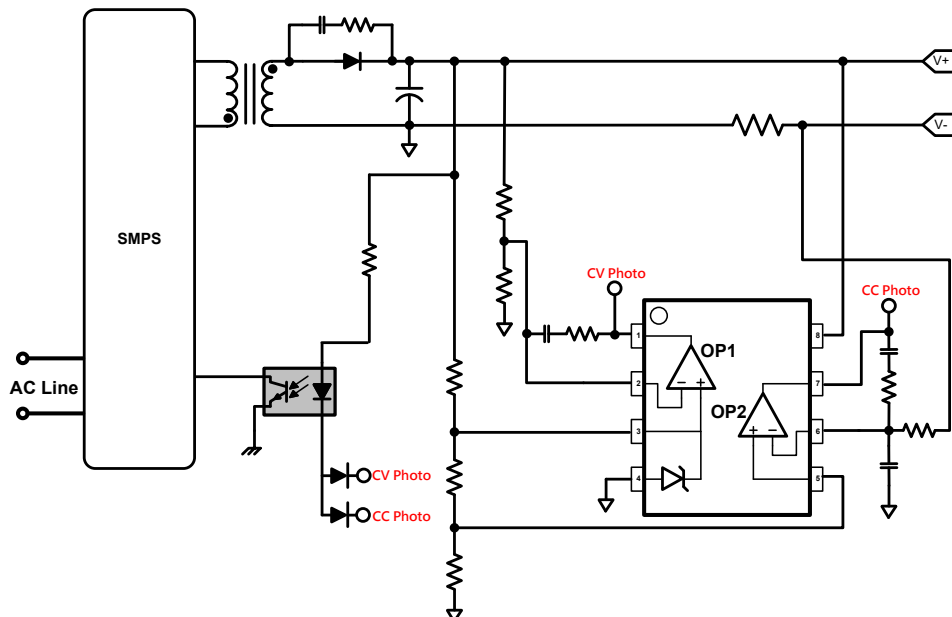

Figure 5. Flyback PWM Control Use IN1V002B1 CV/CC (single supply voltage) V_{CC} =System Output Voltage



PACKAGE OUTLINES

SOP-8L

Small Outline Package
UNIT : inch

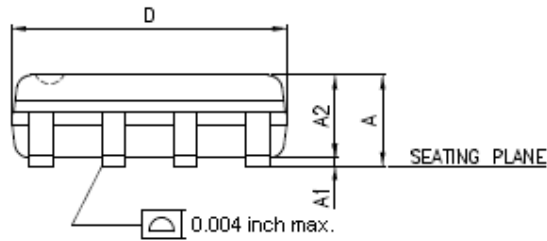
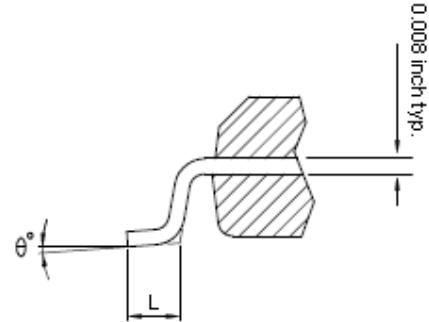
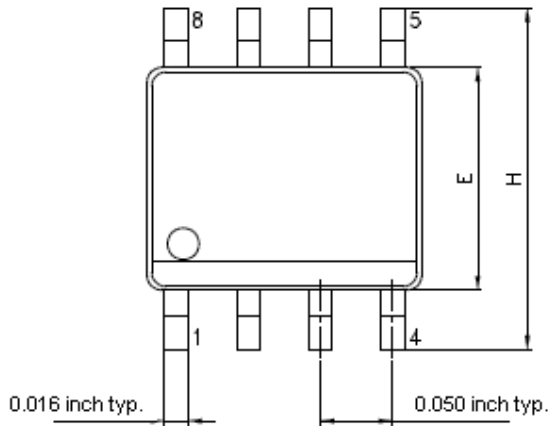

Symbols	Dimensions In Inches			Dimensions In millimeters		
	MIN.	NOR.	MAX.	MIN.	NOR.	MAX.
A	0.050	0.061	0.072	1.270	1.549	1.829
A1	0.000	-----	0.010	0.000	-----	0.254
A2	-----	-----	0.062	-----	-----	1.575
D	0.185	0.193	0.200	4.699	4.902	5.080
E	0.147	0.154	0.160	3.734	3.912	4.064
H	0.225	0.237	0.249	5.715	6.020	6.325
L	0.013	0.033	0.053	0.330	0.838	1.346
θ	0°	4°	8°	0°	4°	8°

TSSOP-8

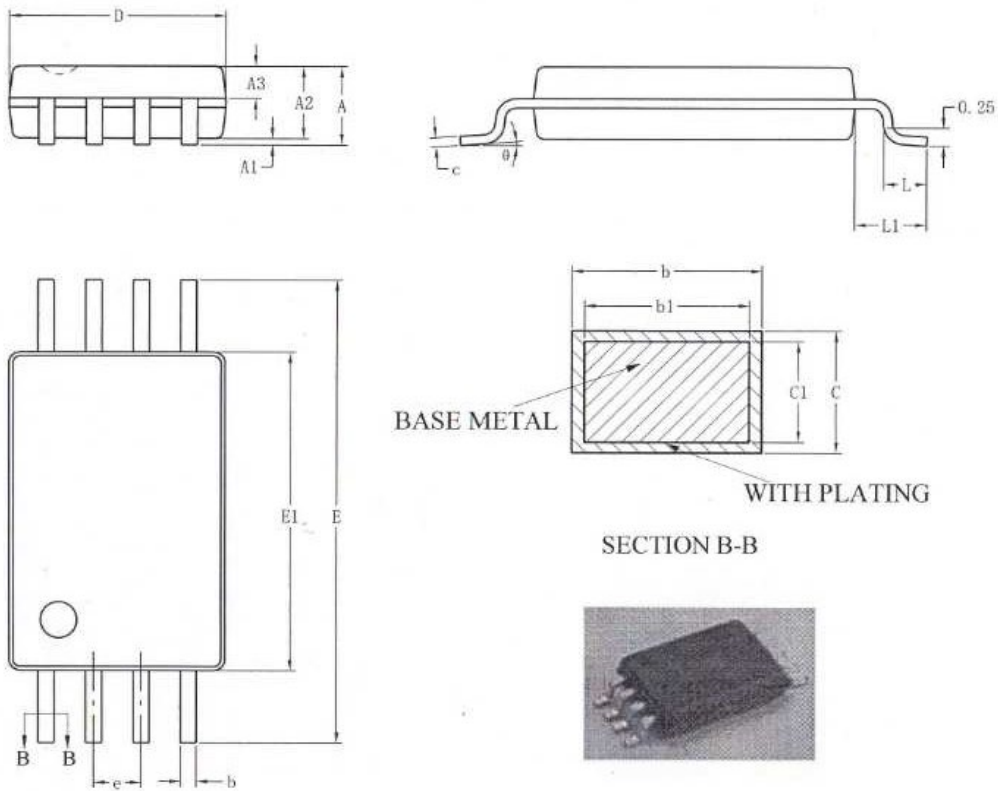

SYMBOL	MILLIMETER		
	MIN	NOM	MAX
A	—	—	1.20
A1	0.05	—	0.15
A2	0.90	1.00	1.05
A3	0.39	0.44	0.49
b	0.20	—	0.28
b1	0.19	0.22	0.25
c	0.13	—	0.17
c1	0.12	0.13	0.14
D	2.90	3.00	3.10
E1	4.30	4.40	4.50
E	6.20	6.40	6.60
e	0.65BSC		
L	0.45	—	0.75
L1	1.00REF		
θ	0	—	8°

SHIPPING PACKING :

★SOP-8 tape & Reel:

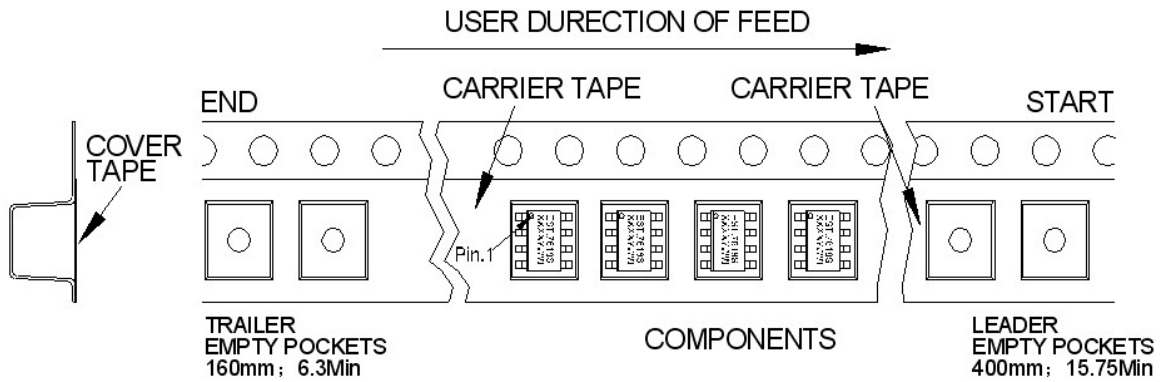

1Pc / device

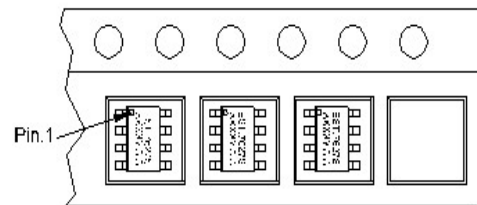
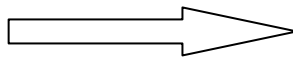

2500 devices / Reel

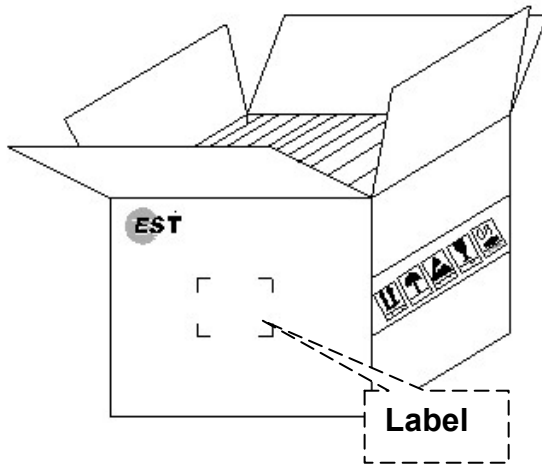

12 Reel / Carton
(30,000Pcs / Carton)

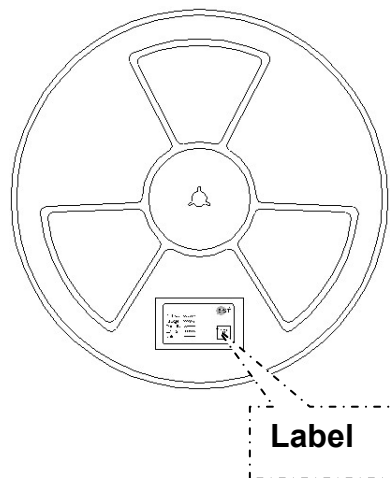

EMBOSSED TAPE AND REEL DATA CARRIER TAPE SPECIFICATIONS

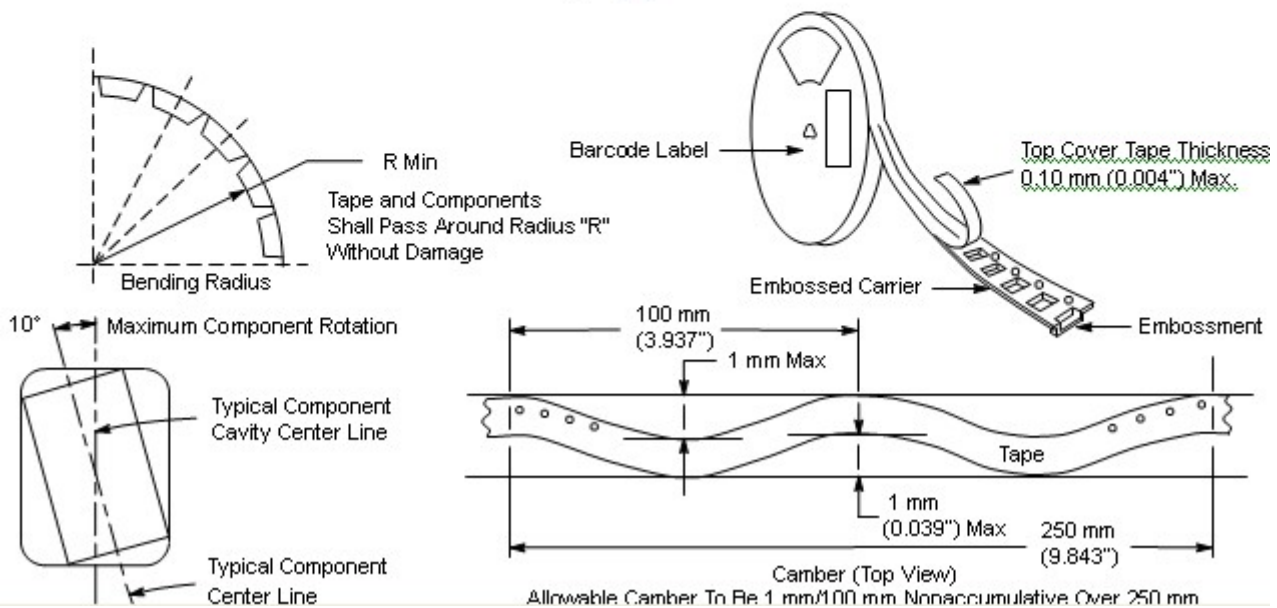
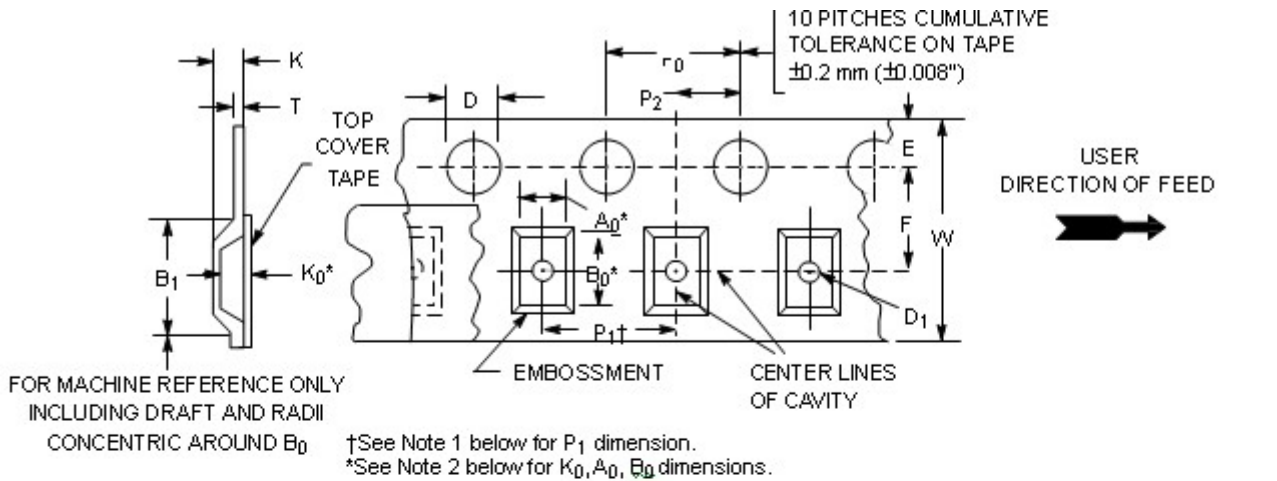

DIMENSIONS

Tape	B_1 Max (Note 1)	D	D_1	E	F	K	P_0	P_2	R Min	T Max	W Max	
8 mm	4.55 mm (0.1793)	1.5 ± 0.1 mm - 0.0 (0.059 + 0.0043 - 0.0)	1.0 Min (0.0393) or 0.5 mm Min (0.0203)	1.75 ± 0.1 mm (0.069 ± 0.0043)	3.5 ± 0.05 mm (0.138 ± 0.0023)	2.4 mm Max (0.0943)	4.0 ± 0.1 mm (0.157 ± 0.0043)	2.0 ± 0.1 mm (0.079 ± 0.0023)	25 mm (0.983)	0.6 mm (0.0243)	8.3 mm (0.3273)	
12 mm	8.2 mm (0.3233)		1.5 mm Min (0.0603)			5.5 ± 0.05 mm (0.217 ± 0.0023)					6.4 mm Max (0.2523)	12 ± 0.30 mm (0.470 ± 0.0123)
16 mm	12.1 mm (0.4763)		7.5 ± 0.10 mm (0.295 ± 0.0043)			7.9 mm Max (0.3113)					16.3 mm (0.6423)	
			11.5 ± 0.1 mm (0.453 ± 0.0043)			11.9 mm Max (0.4683)					24.3 mm (0.9573)	

REEL DIMENSIONS

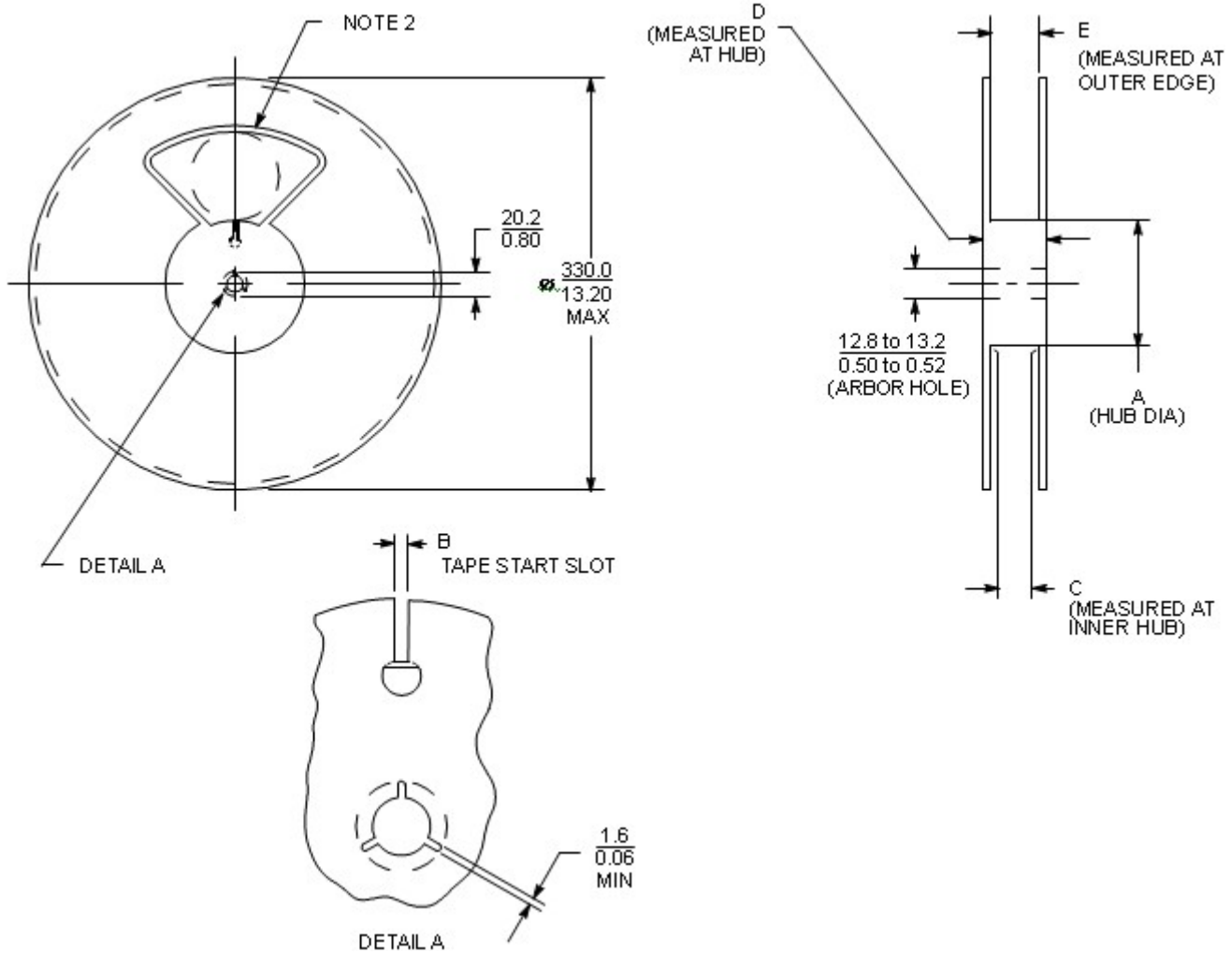

Reel	Tape	A		B		C		D	E
		Min	Max	Min	Max	Min	Max		
178.0 (7.01)	16.0 (0.63)		50.0 (1.97)	6.5 (0.26)	7.5 (0.30)	16.4 (0.65)	18.4 (0.72)	22.4 (0.88)	19.4 (0.76)
330.0 (12.99)	12.0 (0.47)	178.0 (7.01)		4.5 (0.18)	5.5 (0.22)	12.4 (0.49)	14.4 (0.57)	18.4 (0.72)	15.4 (0.61)
330.0 (12.99)	56.0 (2.20)	150.0 (5.91)		10.0 (0.39)	11.0 (0.43)	56.4 (2.22)	58.4 (2.30)	62.4 (2.46)	59.4 (2.34)
330.0 (12.99)	44.0 (1.73)	100.0 (3.94)		10.0 (0.39)	11.0 (0.43)	44.4 (1.75)	46.4 (1.83)	62.4 (2.46)	47.4 (1.87)
330.0 (12.99)	32.0 (1.26)	100.0 (3.94)		10.0 (0.39)	11.0 (0.43)	32.4 (1.28)	34.4 (1.35)	38.4 (1.51)	35.4 (1.39)
330.0 (12.99)	24.0 (0.94)	60.0 (2.36)		9.5 (0.37)	10.5 (0.41)	24.4 (0.96)	26.4 (1.04)	30.4 (1.51)	27.4 (1.08)
330.0 (12.99)	16.0 (0.63)			6.5 (0.26)	7.5 (0.30)	16.4 (0.65)	18.4 (0.72)	22.4 (0.88)	19.4 (0.76)
330.0 (12.99)	12.0 (0.47)			4.5 (0.18)	5.5 (0.22)	12.4 (0.49)	14.4 (0.57)	18.4 (0.72)	15.4 (0.61)
330.0 (12.99)	8.0 (0.31)	50.0 (1.97)		2.5 (0.10)	3.5 (0.14)	8.4 (0.33)	9.9 (0.39)	14.4 (0.57)	10.9 (0.43)
178.0 (7.01)	12.0 (0.47)	50.0 (1.97)		4.5 (0.18)	5.5 (0.22)	12.4 (0.49)	14.4 (0.57)	18.4 (0.72)	15.4 (0.61)
178.0 (7.00)	8.0 (0.31)	50.0 (1.97)		2.5 (0.10)	3.5 (0.14)	8.4 (0.33)	9.9 (0.39)	14.4 (0.47)	10.9 (0.43)
330.0 (12.99)	8.0 (0.31)	50.0 (1.97)		4.0 (0.16)	5.0 (0.20)	8.4 (0.33)	9.9 (0.39)	14.4 (0.57)	10.9 (0.43)
178.0 (7.00)	8.0 (0.31)	50.0 (1.97)		4.0 (0.16)	5.0 (0.20)	8.4 (0.33)	9.9 (0.39)	14.4 (0.57)	10.9 (0.43)

EST.4310A

Low Offset Voltage Dual Operational Amplifier



© <http://www.esthome.com>

© 2016 est Printed in Taiwan - All Rights Reserve