

## Data Sheet

---

**Type Description :** Low Offset Voltage Dual  
Operational Amplifier

**Product Name :** EST.4158A

**Reversion :** V1.0

**Reversion Date :** May, 2016

**Page :** 8 Pages

Please note that all data and specifications are subject to change without notice. All the trade marks of products and companies mentioned in this data sheet belong to their respective owners.

## Low Offset Voltage Single Operational Amplifier

### GENERAL DESCRIPTION

The EST.4158A integrates a low power, low offset and high performance independent operational amplifier. It is also specifically designed to operate from a single power supply.

Now, it is available in a tiny SOT-23-5 package

### APPLICATION

- Switching ac/dc adapter and battery charger
- General purpose controllers, instruments

### KEY FEATURE

- ◆ Available in SOT-23-5 package, Halogen & Lead free
- ◆ Rail-to-rail input/output, Wide input common mode range : 0V ~ VCC+
- ◆ Supply range : 6V(+/-3V) to 26V(+/-13V)
- ◆ Supply current : 200uA (@ VCC+ =15V)
- ◆ Low offset voltage :  $\pm 250\mu\text{V}$
- ◆ Low offset voltage drift :  $7\mu\text{V}/^\circ\text{C}$
- ◆ Unity gain bandwidth : 1MHz
- ◆ Common mode rejection : 80dB
- ◆ Hazardous Substance Free
- ◆ RoHs/REACH Compliant

### PIN CONFIGURATION

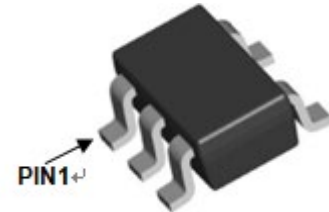
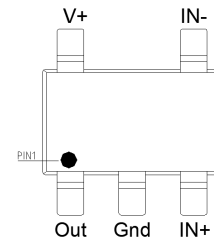

SOT-23-5

### ORDERING INFORMATION

Part Number	Package	Packaging	Note
EST.4158A	SOT-23-5	Tape & Reel	Green

Note: EST lead-free products contain molding compounds/die attach materials and 100% matte tin plate termination finish; which are fully compliant with RoHS. EST lead-free products meet or exceed the lead-free requirements of IPC/JEDEC J-STD-020C for MSL classification at lead-free peak reflow temperature. EST defines "Green" to mean lead-free (RoHS compliant) and halogen free (Br or Cl does not exceed 900ppm by weight in homogeneous material and total of Br and Cl does not exceed 1500ppm by weight).

**APPLICATION CIRCUIT**

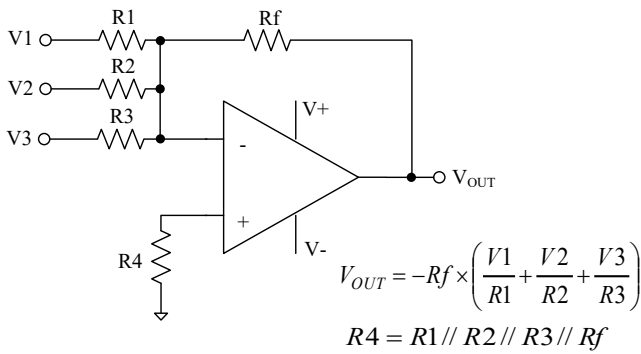

Inverting Summing Amplifier Circuit

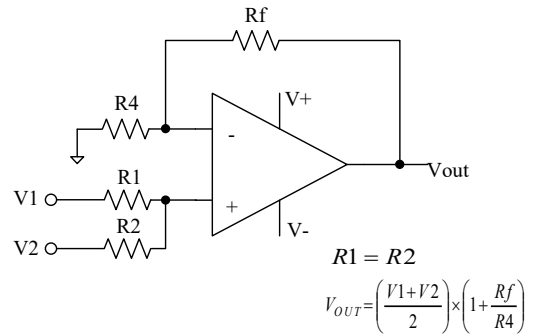

Non-Inverting Summing Amplifier Circuit

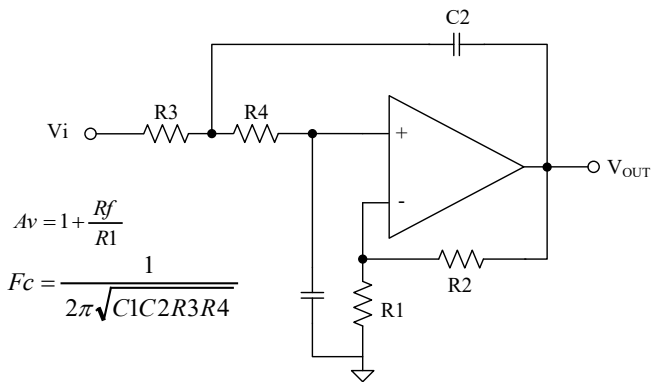

Second Order Active Low-Pass Filter

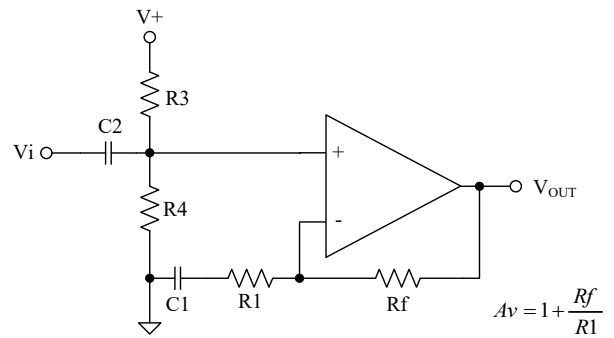

AC Coupled Non-inverting Amplifier

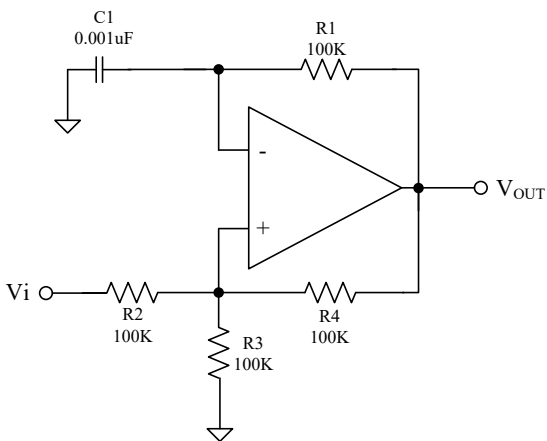

Squarwave Oscillator

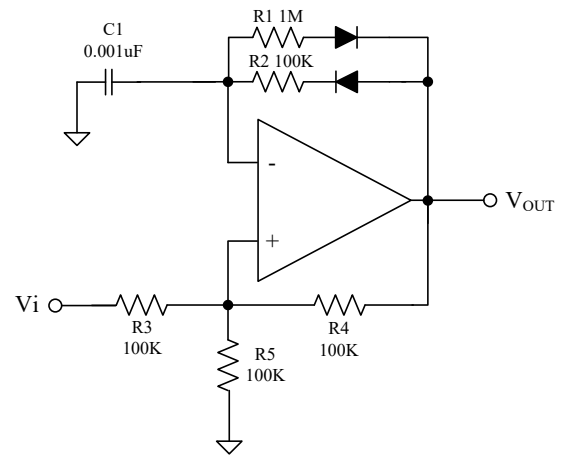

Pulse Generator

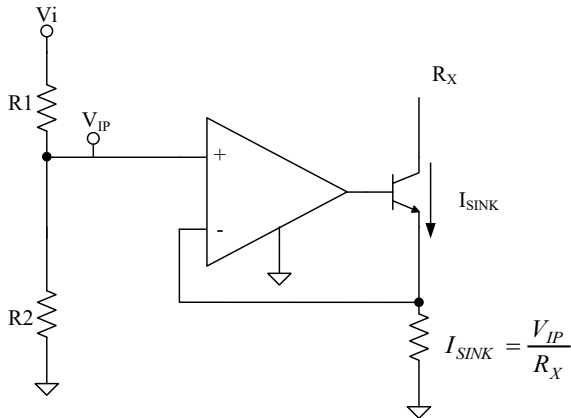

Current Sink

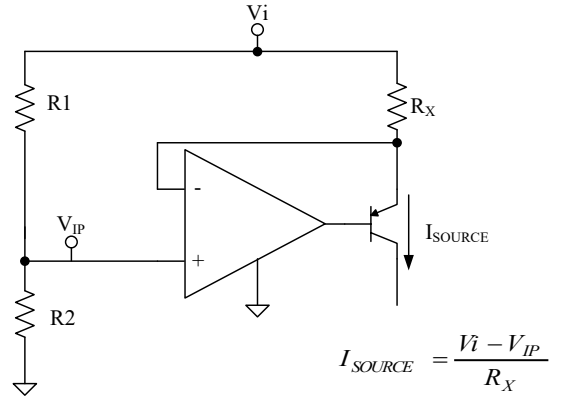

Current Source

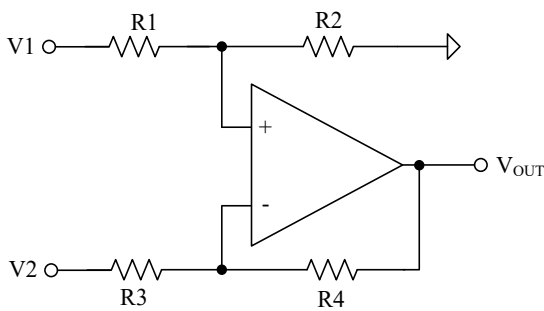

$$R1 = R3, R2 = R4$$

$$V_{OUT} = (V1 - V2) \times \frac{R4}{R3}$$

Differential Amplifier

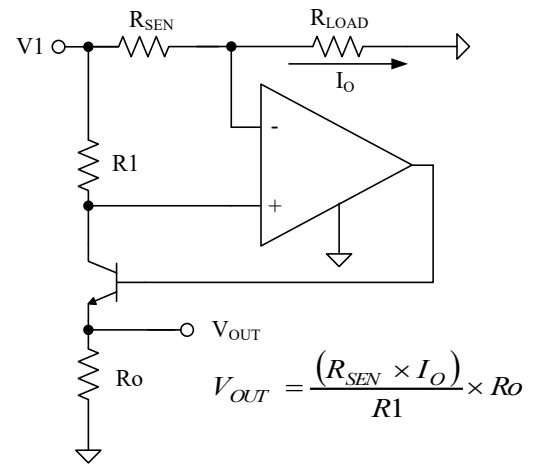

Current Monitor Amplifier

### PIN DESCRIPTION

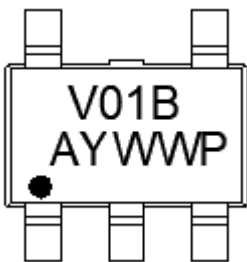

#### Marking:

V01B: 4158  
 A: Production lot code  
 YWWP: Date Code  
     Y=Year;  
     WW=weeks  
 P: series No

SOT-23-5	NAME Description	Description
1	Output	Output of OP AMP.
2	GND	GND
3	IN+	OP Non-inverting Input
4	IN-	OP Inverting Input
5	V+	Positive power supply

## Low Offset Voltage Single Operational Amplifier

### ABSOLUTE MAXIMUM RATINGS

Parameter Symbol	Symbol	Limit Values		Unit	Remark
		Min.	Max		
Supply Voltage Vcc	V <sub>CC</sub>	-0.3	26	V	
Differential Input Voltage	V <sub>ID</sub>		26	V	
Input Voltage	V <sub>i</sub>	-0.6	26	V	
OP Output Voltage	V <sub>o</sub>	-0.3	V <sub>CC</sub>	V	
Operation Junction Temperature	T <sub>j</sub>	-40	150	°C	
Storage Temperature	T <sub>stg</sub>	-55	150	°C	
Package Thermal Resistance	SOT-23-5	θ <sub>JA</sub>	-	245	°C/W
Junction to case Thermal Resistance		θ <sub>JC</sub>		55	°C/W
Power Dissipation @TA=25°C	SOT-23-5	PD	-	0.4	W
Lead temperature (Soldering, 10 sec)			-	260	°C
ESD Voltage Protection	HBM	VESD-HBM	-	2.0	KV
	MM	VESD-MM	-	200	V

Stress beyond those listed under "Absolute Maximum Ratings" may cause permanent damage to the device. These are stress ratings only, and functional operation of the device at these or any other conditions beyond those indicated in the operational sections of the specifications is not implied. Exposure to absolute maximum rating conditions for extended periods may affect device reliability.

\*Free standing with no heatsink; without copper clad.(Measurement condition – just before junction temperature T<sub>J</sub> enters into OTP)

\*\*Measure on the PKG top surface

### DC ELECTRICAL CHARACTERISTICS (V<sub>CC</sub><sup>+</sup> =15V, V<sub>CC</sub><sup>-</sup> =0V Ta=25°C)

Parameter	Symbol	Min.	Typ.	Max.	Unit	Conditions
Positive Supply Voltage	V <sub>CC</sub> <sup>+</sup>	6		25	V	
Total Supply Current	I <sub>CC</sub>			200	μA	1. V <sub>CC</sub> <sup>+</sup> = 15V 2. no load,
Input Offset Voltage	V <sub>IO</sub>	-250 -350	0 0	250 350	μV	25°C -25~85°C
Small Signal Gain	A <sub>vd</sub>		80		dB	
Common Mode Rejection Ratio	CMRR			80	dB	
Power Supply Rejection Ratio	PSRR			80	dB	
Input Common Mode Voltage Range	V <sub>ICM</sub>	0		V <sub>CC</sub>	V	V <sub>CM</sub> =0V to V <sub>CC</sub> . R <sub>S</sub> ≤10KΩ
Output Current Source	I <sub>source</sub>			10	mA	1. V <sub>ID</sub> = +1V 2. V <sub>CC</sub> <sup>+</sup> = 15V 3. V <sub>O</sub> = 2V
Output Current Sink	I <sub>sink</sub>			15	mA	1. V <sub>ID</sub> = -1V 2. V <sub>CC</sub> <sup>+</sup> = 15V 3. V <sub>O</sub> = 2V
Output Short Circuit Current to Ground	I <sub>sc</sub>			10	mA	V <sub>CC</sub> <sup>+</sup> = 15V
High Level Output Voltage	V <sub>OH</sub>			V <sub>CC</sub>	V	1. R <sub>L</sub> = 10K 2. V <sub>CC</sub> <sup>+</sup> = 15V
Low Level Output Voltage	V <sub>OL</sub>		20		mV	R <sub>L</sub> = 10K
Slew Rate at Unity Gain	SR		0.5		V/us	1. V <sub>i</sub> = 0.5 to 3V 2. V <sub>CC</sub> <sup>+</sup> = 15V 3. R <sub>L</sub> = 2K 4. C <sub>L</sub> = 100pF 5. unity gain connection
Gain Bandwidth Product	GBP		1		MHz	1. f = 100KHz 2. V <sub>CC</sub> <sup>+</sup> =15V 3. R <sub>L</sub> = 2K 4. C <sub>L</sub> = 100pF

### BLOCK DIAGRAM

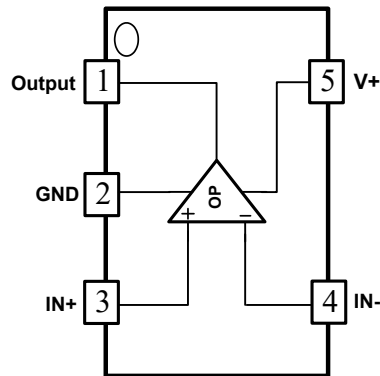

### CAUTION

This integrated circuit has been designed carefully in the ESD protection ability. Failure to observe proper handling and installation procedures may cause damage. Recommend that all integrated circuits should be handled with appropriate precautions.

### PACKAGE OUTLINES

#### SOT23-5

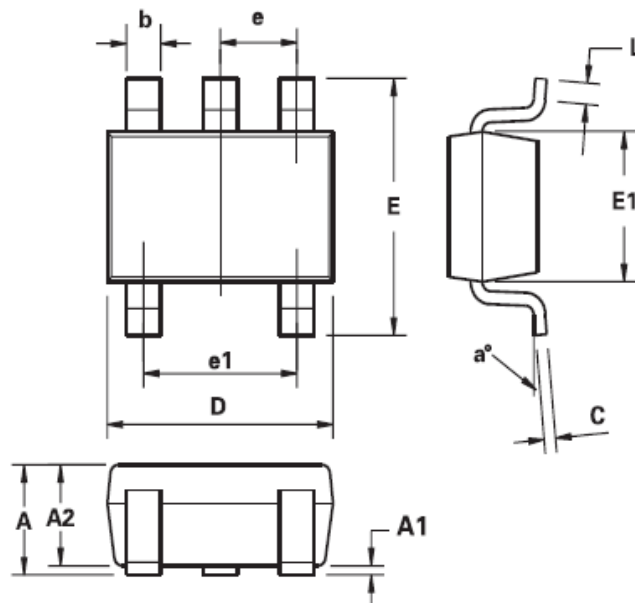

DIM	Millimeters	
	Min.	Max.
A	0.90	1.45
A1	0.00	0.15
A2	0.90	1.30
b	0.20	0.50
C	0.09	0.26
D	2.70	3.10
E	2.20	3.20
E1	1.30	1.80
e	0.95 REF	
e1	1.90 REF	
L	0.10	0.60
a°	0°	30°

## Low Offset Voltage Single Operational Amplifier

### TAPE REEL DATA

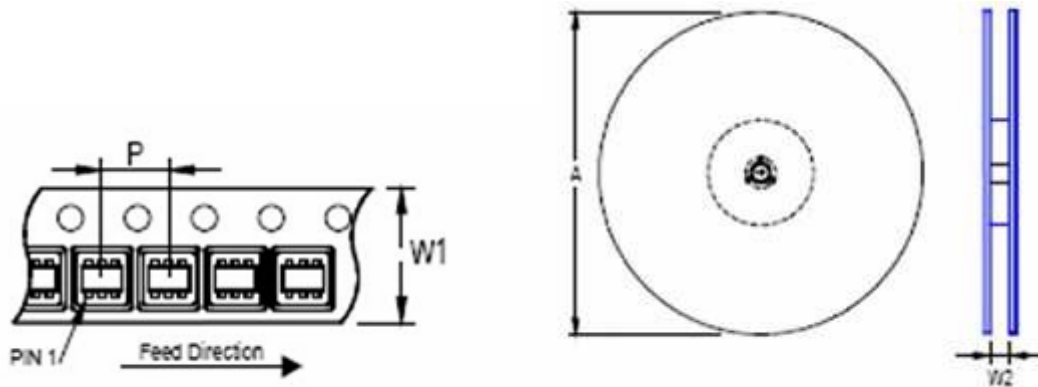

Package Type SOT-26	Tape Size (W1) (mm)	Pocket Pitch (P) (mm)	Reel Size (A) (mm)	Reel Width (W2) Min./Max. (mm)	Units Per Reel pcs.
6 Lead	8	4	180	8.4/9.9	3000

### WAVE SOLDERING PROCESS

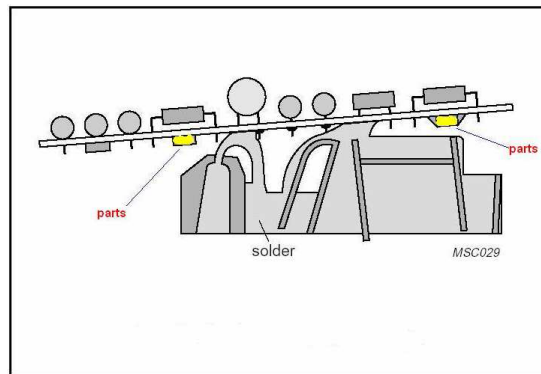

### WAVE SOLDERING PROFILE

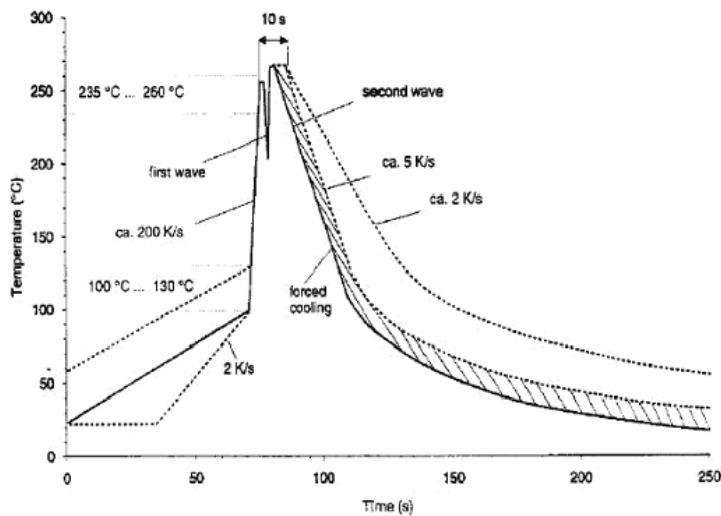

Double-Wave-Soldering, Temperature/Time - Profile  
(Lead-Temperature)  
Full line: typical process / Dotted line: process limits

### UPDATE HISTORY

Revision	Date	Update
1.0	May 06, 2018	Preliminary version



© <http://www.esthome.com>

© 2016 EST Printed in China - All Rights Reserve