

Data Sheet

Type Description : Green-Mode PWM Controller (SSR)

Product Name : EST.28xxDM

Reversion : V1.1

Reversion Date : May, 2020

Page : 15 Pages

EST.28xxDM

Green-Mode PWM Controller (SSR)



General Description

EST.28xxDM is a higher integrated PWM flyback controller. It provides several functions to enhance the efficiency to meets the criteria of global standards such as DoE Level VI and EU CoC V5 Tier-2. Meantime, it also provides excellent EMI-improved solution, and also built in complete protection.

EST.28xxDM is a green mode controller, which implements low start-up current, green-mode power-saving. It is also built-in the leading-edge blanking (LEB) of the current sensing and feedback loop to screen the spike noise from any input signal. The internal slope compensation can limit the constant output over universal AC input range. The sawtooth over frequency function for EMI improved solution.

Meanwhile, EST.28xxDM also provides various protection, such as, OLP (Over Load Protection), VDD OVP (Over Voltage Protection), Output OLP and output OVP to prevent the circuit damage from the abnormal conditions.

EST.28xxDM is available in DIP-8.

EST.28xxDM works with current sensing synchronous rectifier controllers, such as EST.6001C and EST.6xxAxx to achieve higher conversion efficiency and very compact power density..

Application

- Switching AC/DC adapter and battery charger
- ATX standby power
- Open frame switching power and CD(R)
- Set-top-boxes(STB) 384Xreplacement

Features

- Integrated high voltage MOSFET
- 65KHz fix frequency mode at PWM Mode
- Very low startup current (<3 uA)
- 0.5mA ultra-low operating current at light load
- Current mode control with Cycle-by-Cycle current limit
- Built-in slope and load regulation compensation
- LEB (Leading-edge blanking) on CS Pin
- UVLO (Under voltage lockout)
- Fault Protections : VDD Over Voltage, CS OVP(Over Voltage), Output Short-Circuit, Over-Current, OLP (Over load protection) and Pin Fault
- Photo coupler short protection & Feedback open protection
- High voltage CMOS process with excellent ESD protection
- 250mA/500mA driving capability
- Hazardous Substance Free
- RoHs/REACH Compliant

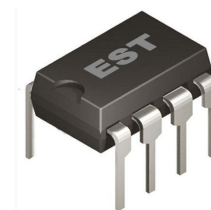

DIP-8L

Function and Protection Options

Part No.	Package	Freq. KHZ	Protection					
			OLP	VDD. OVP	AUX. OVP	CS. OVP	CS. Open	SDSP
EST.28xxDM	DIP-8	65KHz	Hiccup / 100mS	Hiccup	Hiccup	Hiccup	Hiccup	Hiccup

Note: EST lead-free products contain molding compounds/die attach materials and 100% matte tin plate termination finish; which are fully compliant with RoHS. EST lead-free products meet or exceed the lead-free requirements of IPC/JEDEC J-STD-020C for MSL classification at lead-free peak reflow temperature. EST defines "Green" to mean lead-free (RoHS compliant) and halogen free (Br or Cl does not exceed 900ppm by weight in homogeneous material and total of Br and Cl does not exceed 1500ppm by weight)

Ordering Information

Part Number	Package	Packaging	Note
EST.28xxDM	DIP-8L	Tape	Green

EST.28xxDM

Green-Mode PWM Controller (SSR)



Pin Assignments and Package Type

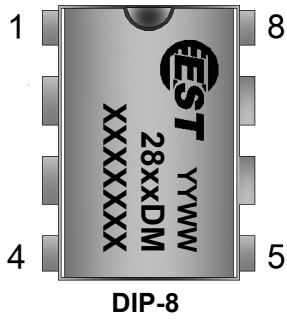

EST: LOGO
 YYWW: Date code
 28xxDM: xx=MOS Type;
 D= Version number
 M= Package Information
 XXXXXXXX: Production lot code

DIP-7	NAME Description	Description
1	GND	Ground
2	CS	Current Sense pin, connect to sense the MOSFET current.
3	VDD	Power supply pin
4	FB	Voltage input pin by connecting a photo-coupler
5,6,7,8	DRAIN	HV MOSFET Drain pin. The Drain pin is connected to the primary lead of the transformer.

Application Circuit

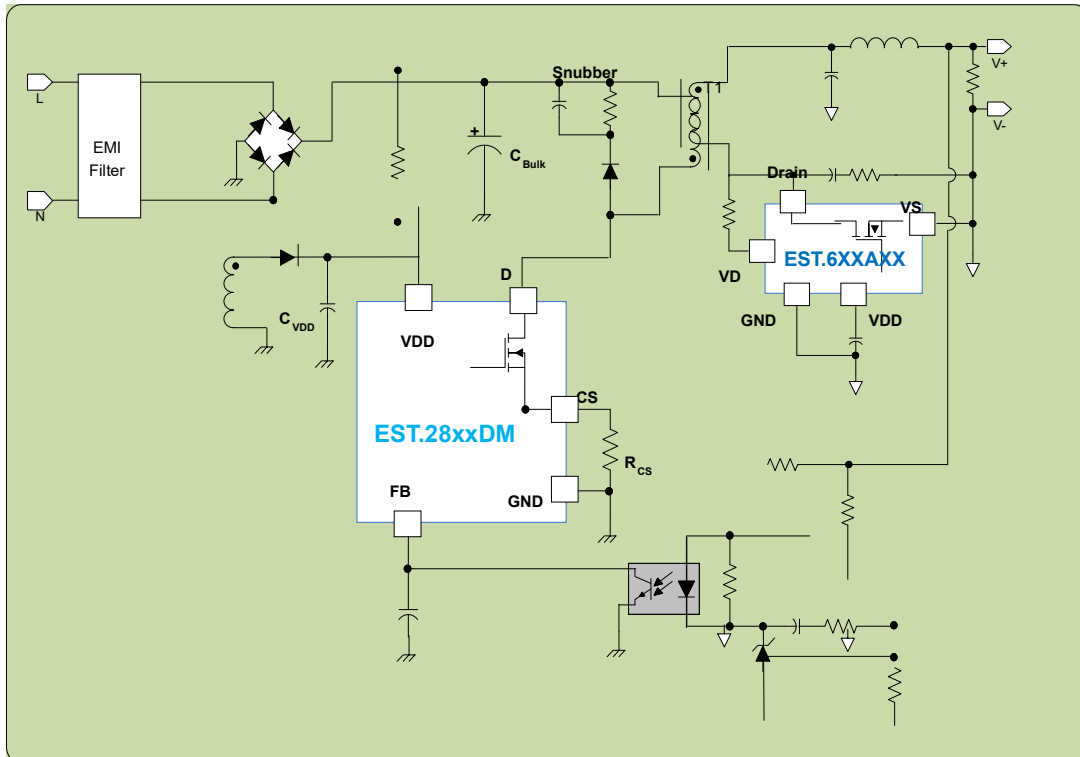

Absolute Maximum Ratings

Parameter Symbol	Symbol	Limit Values		Unit	Remark
		Min.	Max		
Supply Voltage VDD	V _{DD}	-0.3	32	V	
FB,CS Voltage	V _{AC} , V _{FB} , V _{CS} ,	-0.3	7	V	
Drain Voltage	V _D	650		V	
Max Junction Temperature	T _{jm}	-40	150	°C	
Operation Junction Temperature	T _j	-40	125	°C	
Operation Ambient Temperature	T _A	-25	85	°C	
Storage Temperature	T _{stg}	-55	150	°C	
Absolute Max. IDD Current @ V _{DD} =25V	I _{DD_max}	-	22	mA	DIP-8
Power Dissipation	PD	-	1500	mW	
Junction-to-Ambient Thermal Resistance*	θ _{JA}	-	80	°C/W	
Junction-to-Case Thermal Resistance**	θ _{JC}	-	20	°C/W	
Lead temperature (Soldering, 10 sec)		-	260	°C	
ESD Voltage Protection	HBM	V _{ESD-HBM}	-	3.0	KV
	MM	V _{ESD-MM}	-	300	V

Stress beyond those listed under “Absolute Maximum Ratings” may cause permanent damage to the device. These are stress ratings only, and functional operation of the device at these or any other conditions beyond those indicated in the operational sections of the specifications is not implied. Exposure to absolute maximum rating conditions for extended periods may affect device reliability.

Recommended Operating Conditions

Parameter Symbol	Symbol	Limit Values		Unit	Remarks
		Min.	Max		
Operation Junction Temperature	T _{jo}	-40	125	°C	
Supply Voltage V _{DD}	V _{DD}	11	25	V	
Startup Resistor Value	R _{star}	1	14	MΩ	
Ambient temperature range	T _{opr}	-25	85	°C	
Capacitance of CS pin	C _{CS}	47	390	pF	
Capacitance of FB pin	C _{FB}		2.2	nF	

EST.28xxDM

Green-Mode PWM Controller (SSR)



EST.28xxDM Green-Mode PWM Controller (SSR)

DC Electrical Characteristics (VCC =15V, Ta=25°C)

Supply Voltage (VCC Pin):

Parameter	Symbol	Min.	Typ.	Max.	Unit	Conditions
Startup Current	I _{CC-ST}	2	3.5	5.5	μA	UVLO ON - 0.1V
Operating Current (with 1nF load on DRV pin)	I _{CC-OP}	0.4	0.6	0.8	mA	V _{FB} =0V
	I _{CC-OP}	1.5	2	2.5	mA	V _{FB} =2.5V CL=1nF
	I _{CC-OLP}	0.2	0.35	0.5	mA	OLP
UVLO (off)	V _{UVLO-OFF}	7.5	8.0	8.5	V	
UVLO (on)	V _{UVLO-ON}	16		19	V	
V _{DD} OVP Level	V _{OVP}	26	27	28.5	V	
OVP Debounce Time	T _{OVP}		4		cycle	Guarantee by Design
V _{CC} Simulation mode(ON)	V _{CC-HD_ON}	9.7	10.2	10.7	V	
V _{CC} Simulation mode(Off)	V _{CC-HD_OFF}	10.2	10.7	11.2	V	
Latch off mode release Current	I _{DD-LHOFF}			25	uA	Guarantee by Design

Voltage Feedback(FB Pin):

Parameter	Symbol	Min.	Typ.	Max.	Unit	Conditions
Short Circuit Current	I _{zero}	0.1	0.14	0.18	mA	V _{FB} =0V
Open Loop Voltage	V _{FB-OP}	4.8	5	5.2	V	FB pin open
Over Load Protection	V _{OLP}	3.5	4	4.5	V	
Debounce Time of OLP	T _{OLP}	90	100	110	ms	
Burst mode start voltage(on)	V _{BUR_ON}	0.35	0.45	0.55	V	
Burst Mode Hysteresis	V _{BUR_HY}	0.05	0.1	0.15	V	
Green Mode Threshold	F _{th_GR}	35	45	55	KHz	V _{FB} =1.3V

Current Sensing (CS Pin):

Parameter	Symbol	Min.	Typ.	Max.	Unit	Conditions
Leading Edge Blanking Time & Propagation Delay to Output	T _{LEB + T_{PD}}	400	500	600	ns	
Maximum CS Off Voltage	V _{CSTH}	0.65	0.7	0.75	V	
OCP source current	I _{OCP}	240	250	260	uA	Min. Duty
CS Over Voltage Protection	V _{CS_OVP}	0.45	0.5	0.55	V	T = T _{off}
OVP Leading Blanking time	T _{OVP_LEB}		2		us	Guarantee by Design
Internal Slope Compensation	V _{SLP_LP_LEB}		160		mV	
Short Circuit Protection Voltage	V _{SCP}		0.85		V	
Debounce Time of V _{SCP}	T _{SCP}		2		cycle	
Short Circuit Detection Time	T _{SCP}		100		us	

Timer Section:

Parameter	Symbol	Min.	Typ.	Max.	Unit	Conditions
Burst Mode Frequency	F _{Burst}	22		28	KHz	
PWM Mode Frequency	F _{PWM}	61	65	69	KHz	
Voltage stability of Frequency	F _{PSRR}	-1		+1	%	V _{DD} = 11V~25V
Frequency Shuffling Range	F _{jitter}	+/-4	+/-6	+/-8	%	
Maximum duty cycle	D _{MAX}	75	80	85	%	
Internal Soft Startup Time	T _{SS}	10.3	13.2	16	mS	

On chip Thermal shut down:

Parameter	Symbol	Min.	Typ.	Max.	Unit	Conditions
IOTP Level	V _{IOTP}		150		°C	Guarantee by Design
Output High Level	V _{OOTP}		120		°C	

EST.28xxDM

Green-Mode PWM Controller (SSR)



EST.28xxDM Green-Mode PWM Controller (SSR)

SDSP (Secondary diodes short protection):

Parameter	Symbol	Min.	Typ.	Max.	Unit	Conditions
SDSP CS pin level	V_{CS_SDSP}		0.85		V	
De-bounce Cycle	$T_{D_SDSP (*)}$		2		Cycle	Guarantee by Design

650V MOSFET (Drain Pin) :

Parameter	Symbol	Test Conditions	Min.	Typ.	Max.	Unit	Remark	Package
MOSFET Drain-source Breakdown Voltage	BV_{DSS}	VGS=0V ID=250uA	650			V		
Static drain-source on-resistance	$R_{DS(on)}$	VGS=10V ID=0.4A		14	17	Ω	EST.2810DM	DIP-8
		VGS=10V ID=0.5A		9	12	Ω	EST.2812DM	DIP-8
		VGS=10V ID=1A		4.5	5	Ω	EST.2816DM	DIP-8
		VGS=10V ID=1.5A		3.1	3.9	Ω	EST.2818DM	DIP-8
		VGS=10V ID=0.5A		2.2	2.7	Ω	EST.2820DM	DIP-8
		VGS=10V ID=1.0A		1.5	1.8	Ω	EST.2830DM	DIP-8

Block Diagram

EST.28xxD

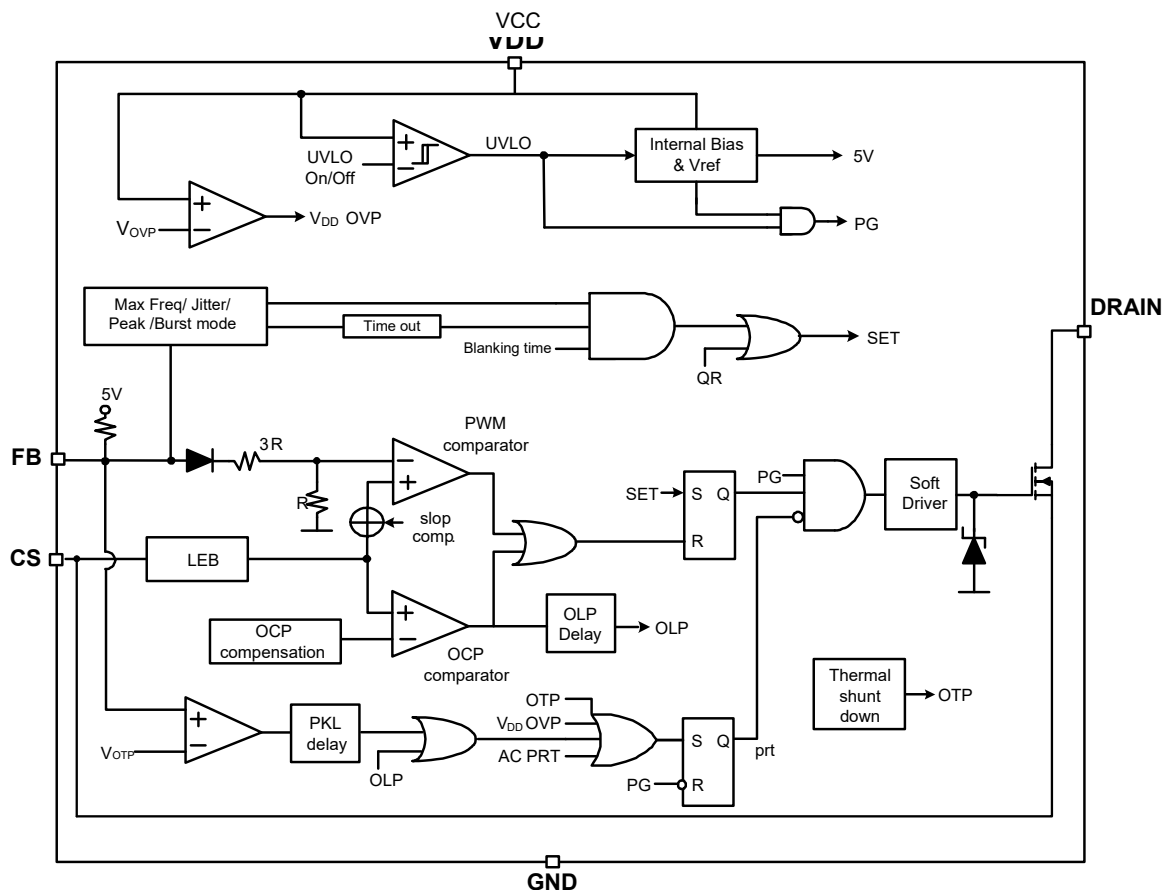

Package Information

DIP-8 Package

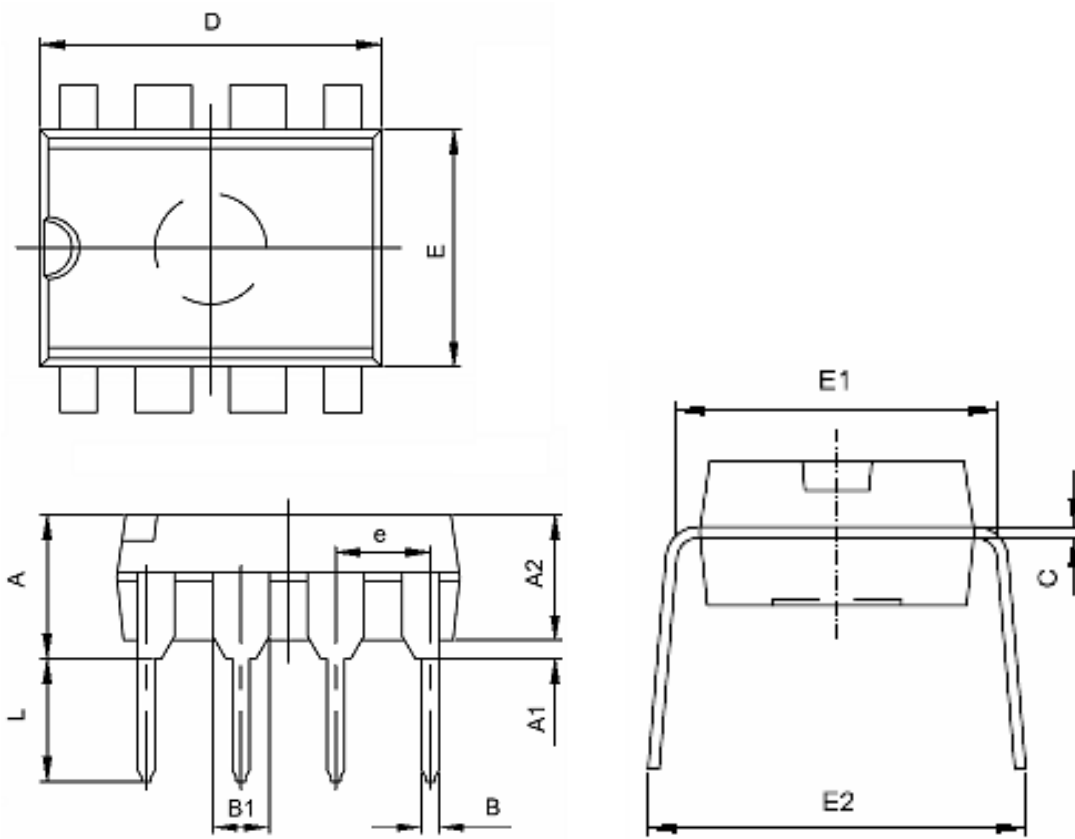

Symbol	Dimensions In Millimeters		Dimensions In Inches	
	Min	Max	Min	Max
A	3.710	4.310	0.146	0.170
A1	0.510		0.020	
A2	3.200	3.600	0.126	0.142
B	0.360	0.560	0.014	0.022
B1	1.524(TYP)		0.060(TYP)	
C	0.204	0.360	0.008	0.014
D	9.000	9.400	0.354	0.370
E	6.200	6.600	0.244	0.260
E1	7.620(TYP)		0.300(TYP)	
e	2.540(TYP)		0.100(TYP)	
L	3.000	3.600	0.118	0.142
E2	8.200	9.400	0.323	0.370

EST.28xxDM
Green-Mode PWM Controller (SSR)



© <http://www.esthome.com>

© 2020 EST Printed in Taiwan - All Rights Reserve