

Description

The EST.2003A is a monolithic high-voltage, high-current Darlington transistor array. The device consists of seven npn Darlington pairs that feature high-voltage outputs with common-cathode clamp diodes for switching inductive loads. The collector-current rating of a single Darlington pair is 500 mA. The Darlington pairs may be paralleled for higher current capability. Applications include relay drivers, hammer drivers, lamp drivers, display drivers (LED and gas discharge), line drivers, and logic buffers. The EST.2003A has a 2.7-kΩ series base resistor for each Darlington pair for operation directly with TTL or 5-V CMOS devices.

The EST.2003A is offered in standard 16-pin dual in-line (N) and surface-mount (D) packaging. The device is characterized for operation over the junction temperature range of -40°C to 105°C.

Feature List

- 500-mA Rated Collector Current (Single Output)
- High-Voltage Outputs . . . 50 V
- Output Clamp Diodes
- Inputs Compatible With Various Types of Logic
- Interchangeable With TI ULQ2003A ULN2001A Series

Ordering information

ORDER NUMBER	Package	Shipping	Top Marking
EST.2003A	DIP-16L(Pb-free)	Tube	EST.2003A
EST.2003AS	SOP-16L(Pb-free)	Tube	EST.2003AS
EST.2003AS	SOP-16L(Pb-free)	Tape & Reel	EST.2003AS

*Design Guarantee: The device is guaranteed to meet the specifications from -40°C to 105°C. Specifications over the -40°C to 105°C operating temperature range are assured by design, characterization and correlation with the statistical process controls.

logic symbol

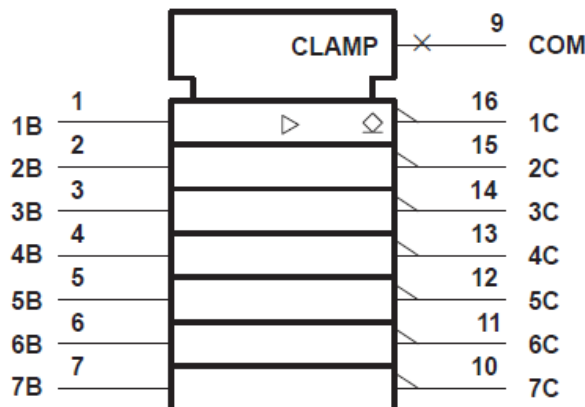

Pin Configuration

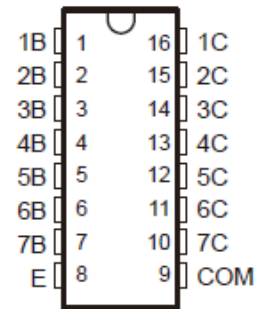

(TOP VIEW)

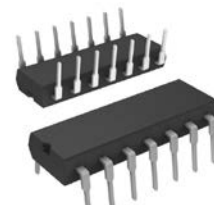
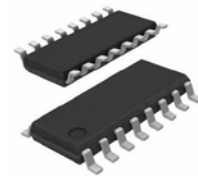

DIP-16L

logic diagram (positive logic)

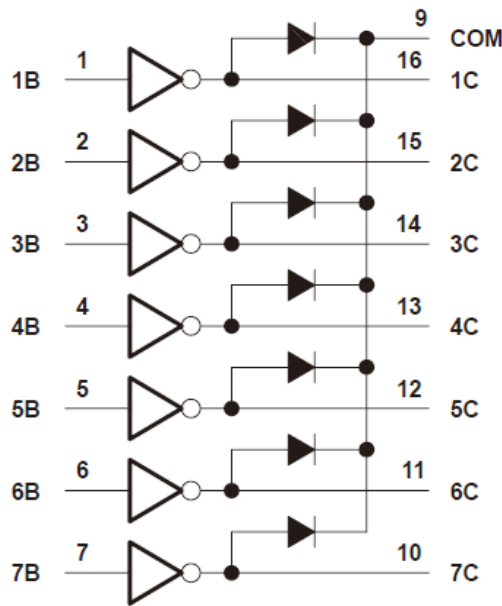

schematics (each Darlington pair)

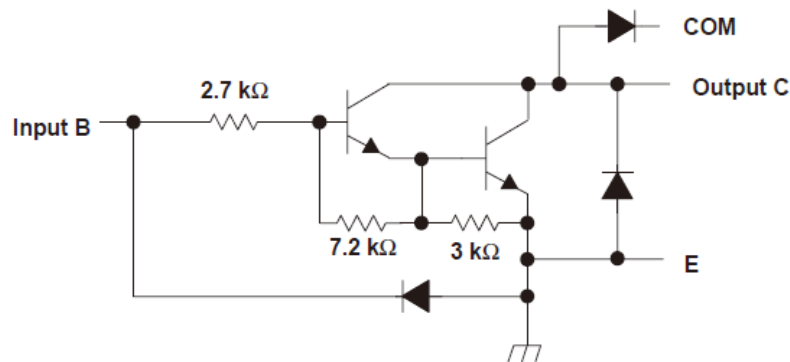

All resistor values shown are nominal.

absolute maximum ratings over operating temperature range (unless otherwise noted)

Collector-emitter voltage	50 V
Clamp diode reverse voltage (see Note 1)	50 V
Input voltage, V_I (see Note 1)	30 V
Peak collector current (see Figures 13 and 14)	500 mA
Output clamp current, I_{OK}	500 mA
Total emitter-terminal current	-2.5 A
Continuous total power dissipation	See Dissipation Rating Table
Operating free-air temperature range, T_A	-40°C to 85°C
Operating junction temperature range, T_J	-40°C to 105°C
Storage temperature range, T_{stg}	-65°C to 150°C
Lead temperature 1,6 mm (1/16 inch) from case for 10 seconds	260°C

Stresses beyond those listed under "absolute maximum ratings" may cause permanent damage to the device. These are stress ratings only, and functional operation of the device at these or any other conditions beyond those indicated under "recommended operating conditions" is not implied. Exposure to absolute-maximum-rated conditions for extended periods may affect device reliability.

NOTE 1: All voltage values are with respect to the emitter/substrate terminal E, unless otherwise noted.

DISSIPATION RATING TABLE

PACKAGE	TA = 25°C POWER RATING	DERATING FACTOR ABOVE TA = 25°C	TA = 85°C POWER RATING
D	950 mW mW	7.6 mW/°C	494 mW
N	1150 mW mW	9.2 mW/°C	598 mW

electrical characteristics over operating junction temperature range TJ = – 40°C to 105°C

PARAMETER		TEST CONDITIONS		MIN	TYP	MA	UNIT
VI(on)	On-state input voltage	VCE = 2 V, See Figure 5	IC = 200 mA			2.7	V
			IC = 250 mA			2.9	
			IC = 300 mA			3	
VCE(sat)	Collector-emitter saturation voltage	II = 250 (A, See Figure 4	IC = 100 mA,		0.9	1.2	V
			IC = 200 mA,		1	1.4	
			IC = 350 mA,		1.2	1.7	
ICEX	Collector cutoff current	VCE = 50 V, See Figure 1	II = 0,			100	(A
VF	Clamp forward voltage	IF = 350 mA,	See Figure 7		1.7	2.2	V
II(off)	Off-state input current	VCE = 50 V, See Figure 2	IC = 500 (A,	30	65		(A
II	Input current	VI = 3.85 V,	See Figure 3		0.93	1.35	mA
IR	Clamp reverse current	VR = 50 V,	See Figure 6			100	(A
Ci	Input capacitance	VI = 0,	f = 1 MHz		15	25	pF

switching characteristics over operating junction temperature, TJ = – 40°C to 105°C

PARAMETER		TEST CONDITIONS		MIN	TYP	MAX	UNIT
tPLH	Propagation delay time, low-to-high-level output	See Figure 8			1	10	us
tPHL	Propagation delay time, high-to-low-level output				1	10	us
VOH	High-level output voltage after switching	VS = 50 V, See Figure 9	IO H 300 mA,	VS-500			mV

PARAMETER MEASUREMENT INFORMATION

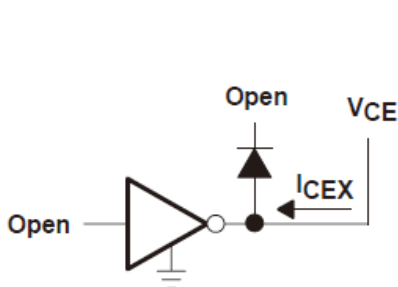

Figure 1. IC EX Test Circuit

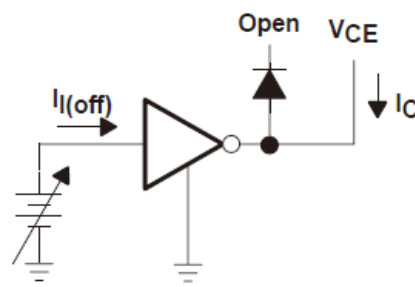

Figure 2. II(off) Test Circuit

PARAMETER MEASUREMENT INFORMATION

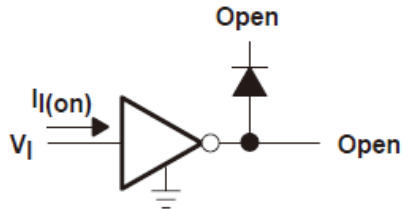

Figure 3. I_I Test Circuit

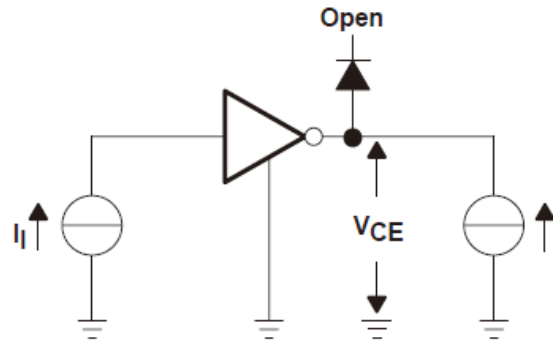

Figure 4. $V_{CE(sat)}$ Test Circuit

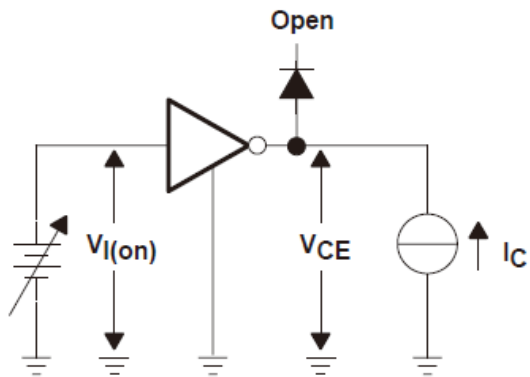

Figure 5. $V_{I(on)}$ Test Circuit

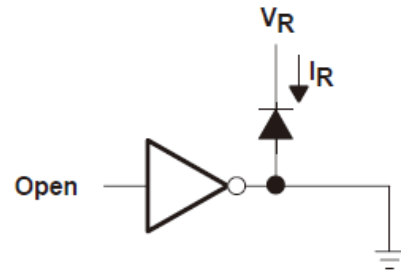

Figure 6. I_R Test Circuit

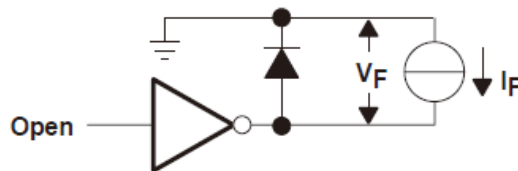

Figure 7. V_F Test Circuit

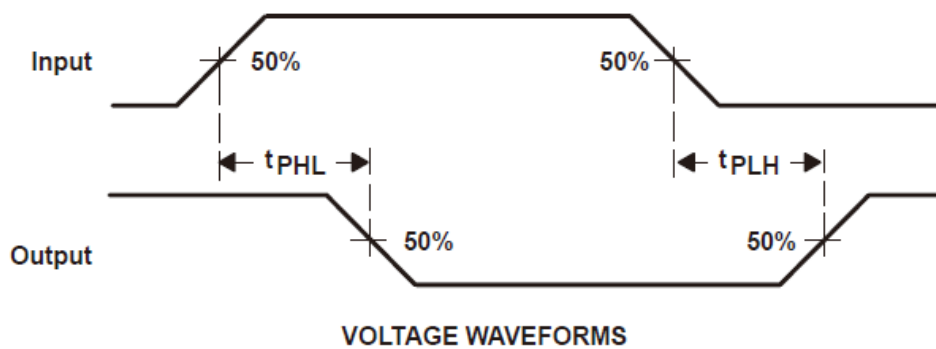
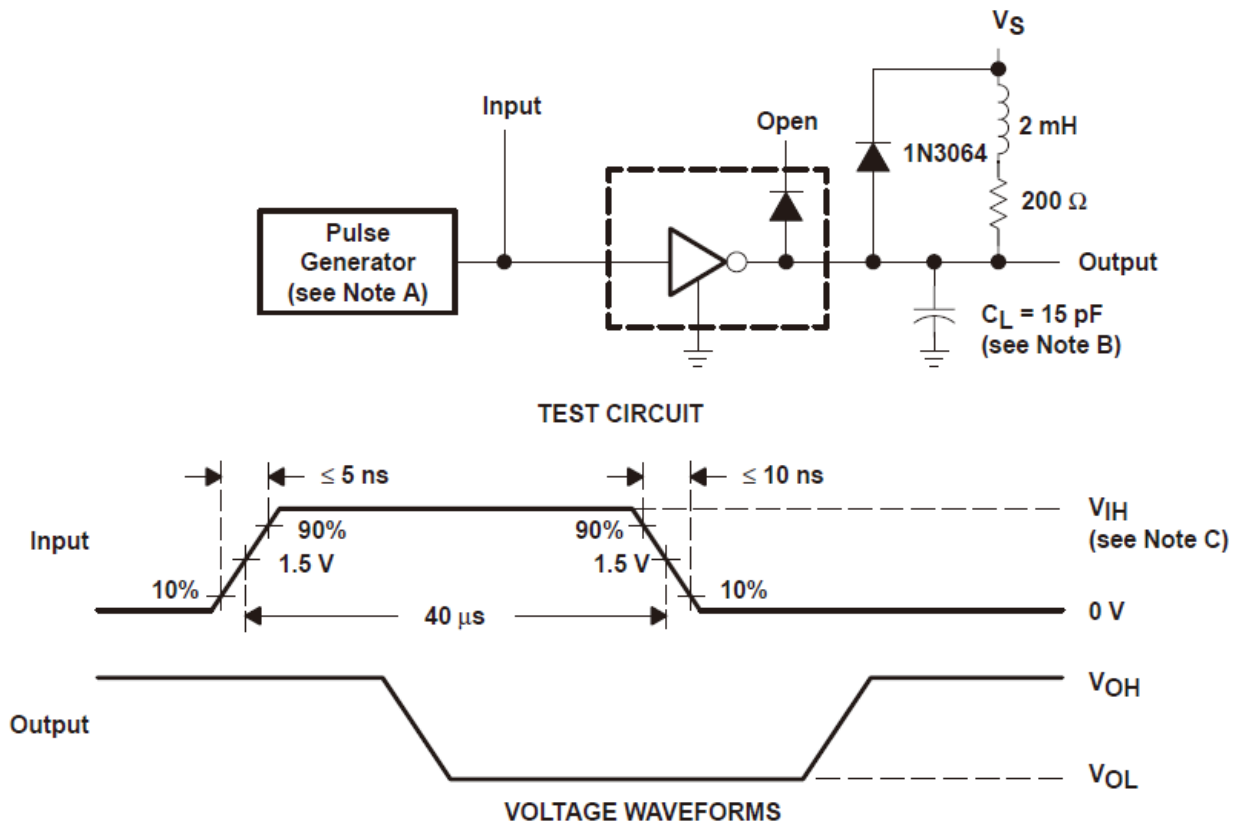

Figure 8. Propagation Delay Time Waveforms

PARAMETER MEASUREMENT INFORMATION



- NOTES: A. The pulse generator has the following characteristics: PRR = 12.5 kHz, $Z_O = 50 \Omega$.
 B. C_L includes probe and jig capacitance.
 C. $V_{IH} = 3 V$

Figure 9. Latch-Up Test Circuit and Voltage Waveforms

TYPICAL CHARACTERISTICS

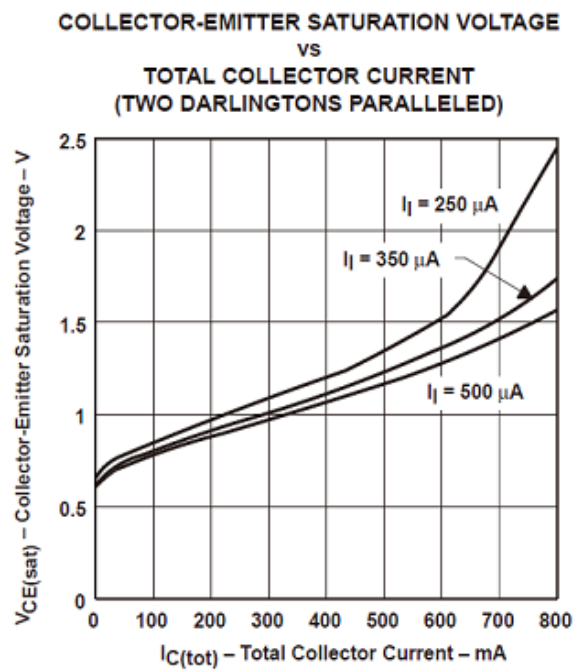
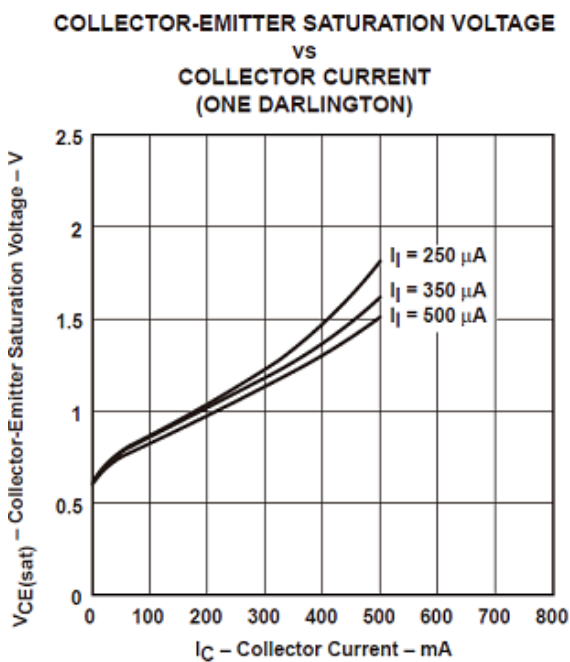

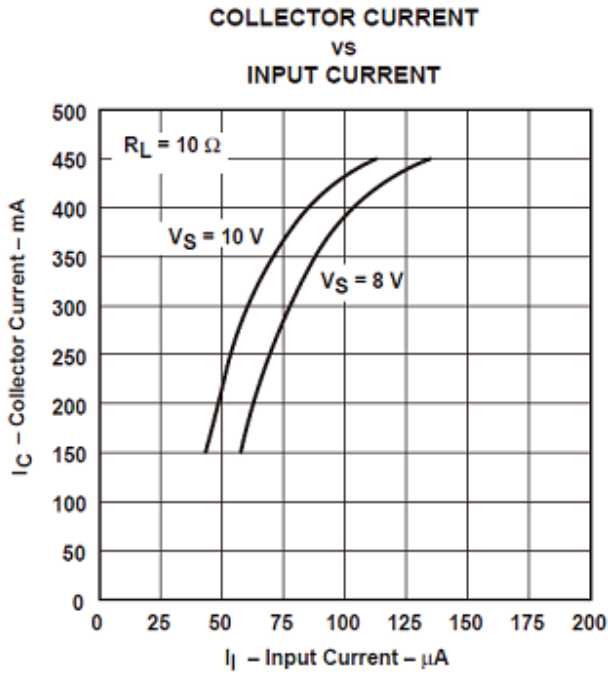

Figure 12

THERMAL INFORMATION

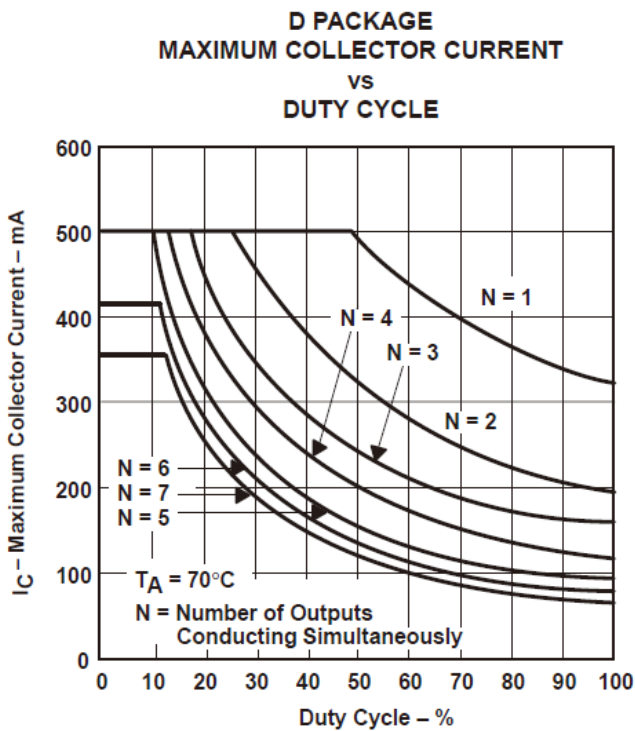

Figure 13

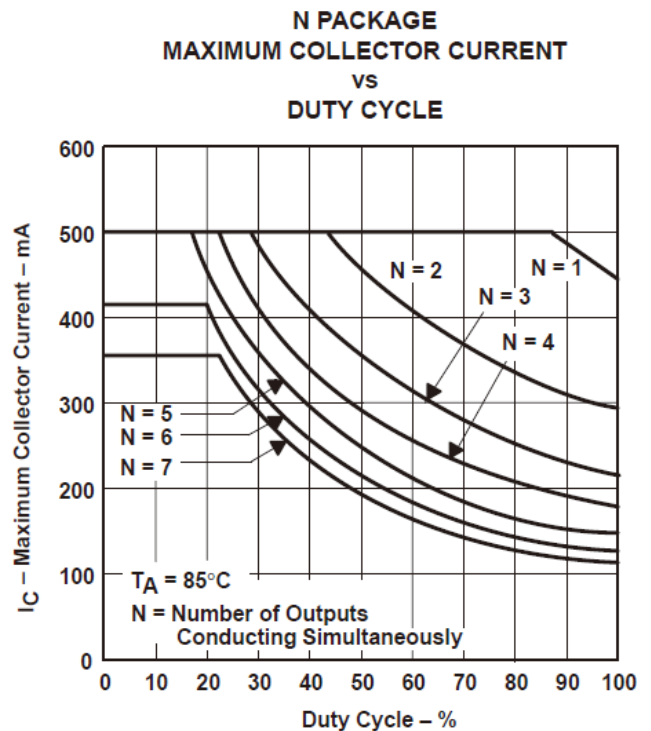

Figure 14

APPLICATION INFORMATION

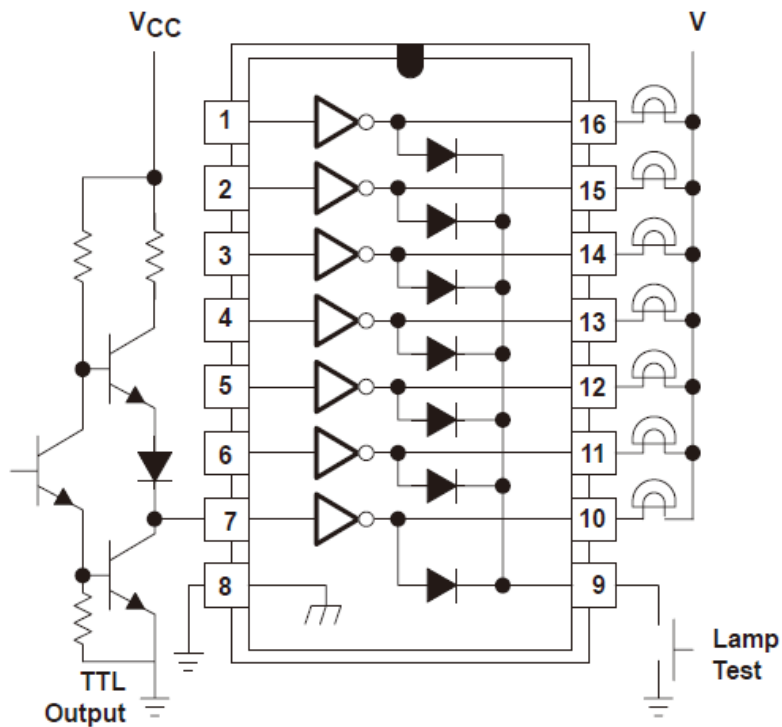

Figure 15. TTL to Load

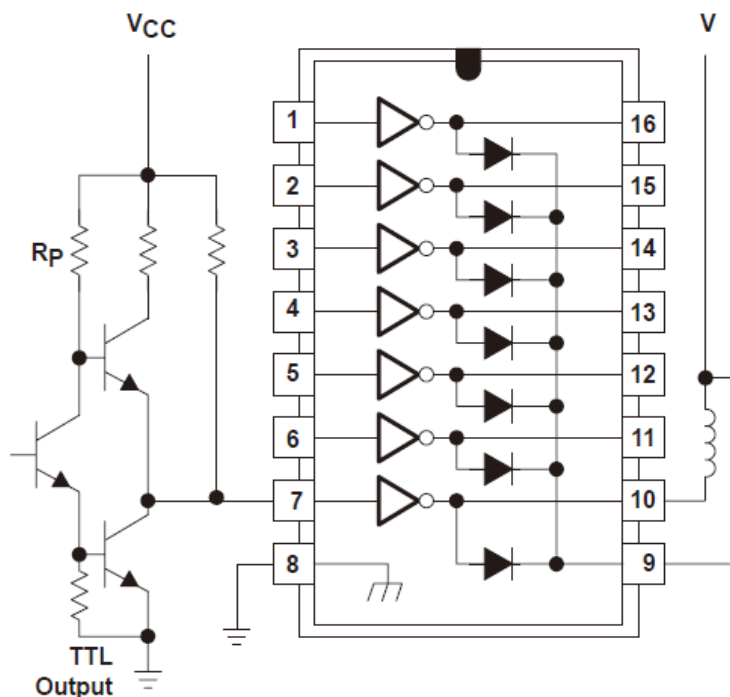

Figure 16. Use of Pullup Resistors to Increase Drive Current



CAUTION

This integrated circuit has been designed carefully in the ESD protection ability. Failure to observe proper handling and installation procedures may cause damage. Recommend that all integrated circuits should be handled with appropriate precautions.

Package Dimensions
SOP-16L

Unit : inch / mm

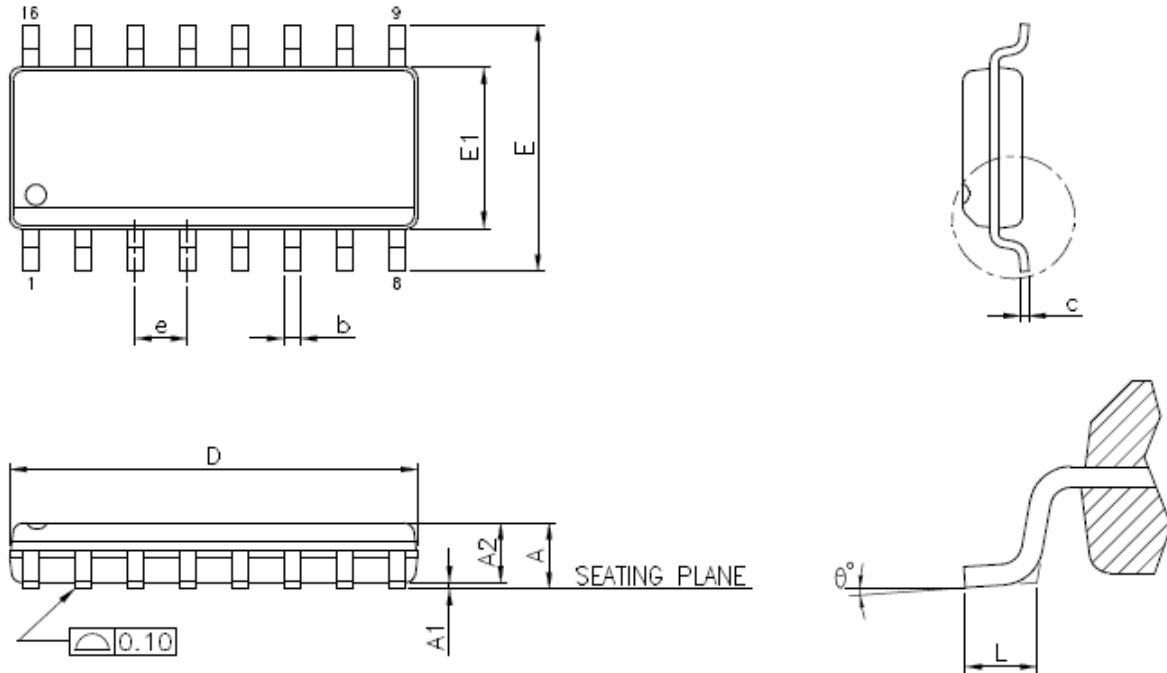

Symbols	Dimensions In inch		Dimensions In millimeters	
	Min.	Max.	Min.	Max.
A	-----	0.072	-----	1.837
A1	0.004	0.010	0.095	0.263
A2	0.047	-----	1.187	-----
b	0.012	0.021	0.294	0.535
c	0.004	0.010	0.095	0.263
D	0.390 BSC		9.900 BSC	
E	0.236 BSC		6.000 BSC	
E1	0.154 BSC		3.900 BSC	
e	0.050 BSC		1.270 BSC	
L	0.015	0.052	0.380	1.333
θ	0°	8°	0°	8°

EST.2003A
DARLINGTON TRANSISTOR ARRAY



DIP-16L

Unit : inch / mm

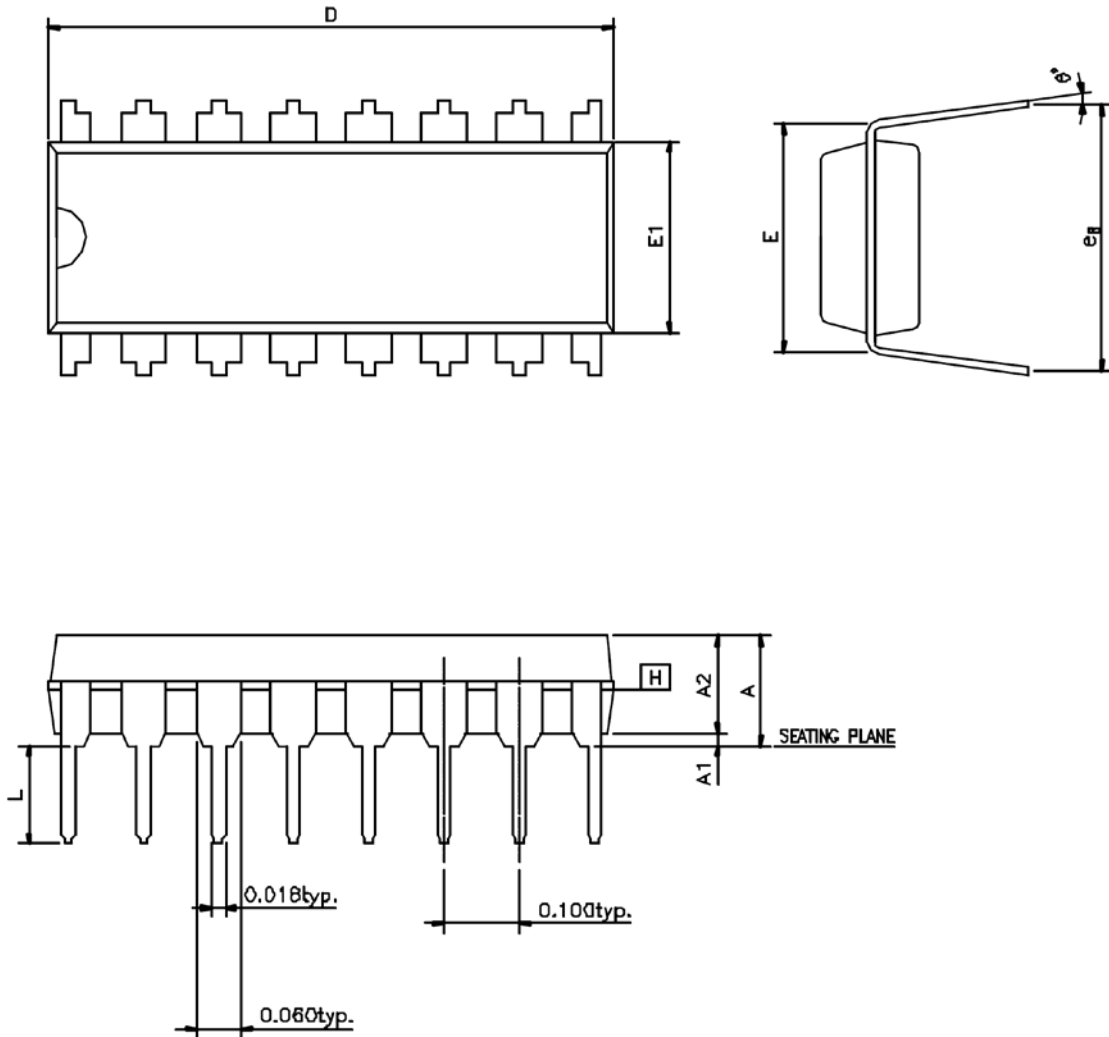

Symbols	Dimensions in inches			Dimensions in millimeters		
	MIN.	NOR.	MAX.	MIN.	NOR.	MAX.
A	---	---	0.215	---	---	5.461
A1	0.010	---	---	0.254	---	---
A2	0.120	0.133	0.145	3.048	3.378	3.683
D	0.730	0.755	0.780	18.542	19.177	19.812
E	0.300 BSC			7.620 BSC		
E1	0.240	0.253	0.265	6.096	6.426	6.731
L	0.110	0.133	0.155	2.794	3.378	3.937
eB	0.320	0.350	0.380	8.128	8.890	9.652
θ	0°	7°	15°	0°	7°	15°

